



# HYDRAULIC COMPONENTS



## Wärmetauscher SS Heat Exchangers SS

COMPANY WITH  
QUALITY SYSTEM  
CERTIFIED BY DNV  
ISO 9001



## SS Serie / Luft-Öl Version

## SS Series / Air-Oil Version

### Radiating mass data

<b>Material</b>	Aluminium
<b>Nominal pressure</b>	25 bar
<b>Test pressure</b>	35 bar
<b>Max temperature</b>	120 °C

### Fluid compatibility

Mineral oils, hl, hlp, water-oil emulsion.

### Installation

We recommend to install a by-pass valve in parallel to the heat exchanger, for its protection during the starting up.  
Make sure there is no obstacle to the air flow.

### Maintenance

#### Oil side cleaning

Flushing with a detergent or a degreasing product compatible with aluminium, eliminates the dirt.  
To remove the residuals, use compressed air.

#### Air side cleaning

It can be done by using compressed air or water and paying attention to the jet direction for not spoiling the vanes. If oil or grease has to be removed, clean with a jet of steam or hot water. Make sure that the electric motor is disconnected and properly protected.

### Materials

<b>Fan</b>	Steel or hard plastic
<b>Fan case</b>	Steel or hard plastic
<b>Fan protection</b>	Steel or hard plastic

## SS Serie / Daten zur Wärmetauscherwahl

### SS Series / Data relating to heat exchanger selection

Here you can find three different series of exchangers:

- series **"SS"** standard
- series **"SS2"** with double passage for reduced flows, but with bigger power of heat exchange
- series **"SD"** for high flows.

On the abscissas you can find the oil flow going through the exchanger, expressed in (lt/min), while on the ordinates you can find the dissipation performance for each centigrade degree, expressed in (kcal/h °C); or in (kW/°C).

The specific dissipation heat ( $\eta$ ) is the result of the ratio between thermic power (Q) of the exchanger and the difference of the temperature between oil input and the ambient temperature (oil T° - air T°), using the following formula:

$$\eta = \frac{Q \text{ (kcal/h)}}{\text{oil T}^\circ - \text{air T}^\circ \text{ (}^\circ\text{C)}}$$

Supposing the exchanger can dissipate 3000 (kcal/h) and you have a temperature difference (oil T° - air T°) = 30 (°C):

$$\eta = \frac{3000 \text{ (kcal/h)}}{30 \text{ (}^\circ\text{C)}} = 100 \text{ (kcal/h }^\circ\text{C)}$$

When the thermic power (Q) of the exchanger is unknown, it is possible to calculate it empirically using the following formula:

$$Q = 0,40 \cdot V \cdot \Delta t_o$$

Where:

V = oil flow in (lt/h)

$\Delta t_o$  = temperature difference between oil in and out

0,40 is an approximate value or it can be used for hydraulic oil (when specific weight and specific heat are unknown).

$$\left[ \begin{array}{l} 0,40 \text{ (kcal/lt}^\circ\text{C)} = c \cdot \gamma \\ \text{dove:} \\ C = \text{specific heat (kcal/kg}^\circ\text{C)} \\ \gamma = \text{specific weight (kg/dm}^3\text{)} \end{array} \right]$$

Supposing the flow is 6000 (lt/h) and the difference between oil in and out ( $\Delta t_o$ ) is 8 (°C) the thermic power of the exchanger is:

$$Q = 0,40 \cdot 6000 \cdot 8 = 19200 \text{ kcal/h}$$

The above curves are valid when the cooler element is activated.

## SS Serie / Typenbezeichnung

### SS Series / Model type

SS20 14 00 A - P

Type
SS10
SS15
SS20
SS24
SS30
SS40
SS50
SS215 (2pass)
SS220 (2pass)
SS224 (2pass)
SS230 (2pass)
SS240 (2pass)
SD20
SD24
SD30
SD40

Bimetallic fixed temperature switches	
00	No switch

To choose switch  
see pages 25 - 26 - 27

Foot flanges / Electric connection	
P	With foot flanges
E	With electric connection
PE	Con staffe di fissaggio e con cablaggio elettrico With foot flanges and with electric connection

**P - PE** applicable only for  
SS10; SS15; SS20; SS24; SS30;  
SS40; SS215; SS220; SS224;  
SS230; SS240.

**E** applicable only for  
SS50; SD20; SD30; SD40.

Fans	
A	Drawing
B	Blowing

Fan Motor	
01	230V 50/60 Hz single phase
03	400V 50/60 Hz three phase ***
14	230/400V 50/60 Hz three phase B14
12	12V CC
24	24V CC
G2	Arranged for hydraulic motor GR.2

\*\*\* SS50 230/400V 50/60 Hz - Three phase

## SS Serie / Technische Daten

### SS Series / Technical features

Tipologia Type	Frequenza Frequency Hz	Tensione Voltage V	N° Giri/min RPM	Potenza Power kW	Diam. Ventola Ø FAN (mm)	dB (A)	L (mm)	Q air (m <sup>3</sup> /h)	Cap. (lt)	Peso Weight (kg)	IP
01	50	220	2600	0.023/0.026	170	52	122	640	0.28	6	54
03	50	380	2490	0.032/0.027	170	52	122	670	0.28	6	54
12	DC	12	4101	0.076	167	71	167	569	0.28	5	68
24	DC	24	4101	0.076	167	71	167	560	0.28	5	68

Suggested oil flow from 5 to 40 (lt/min)

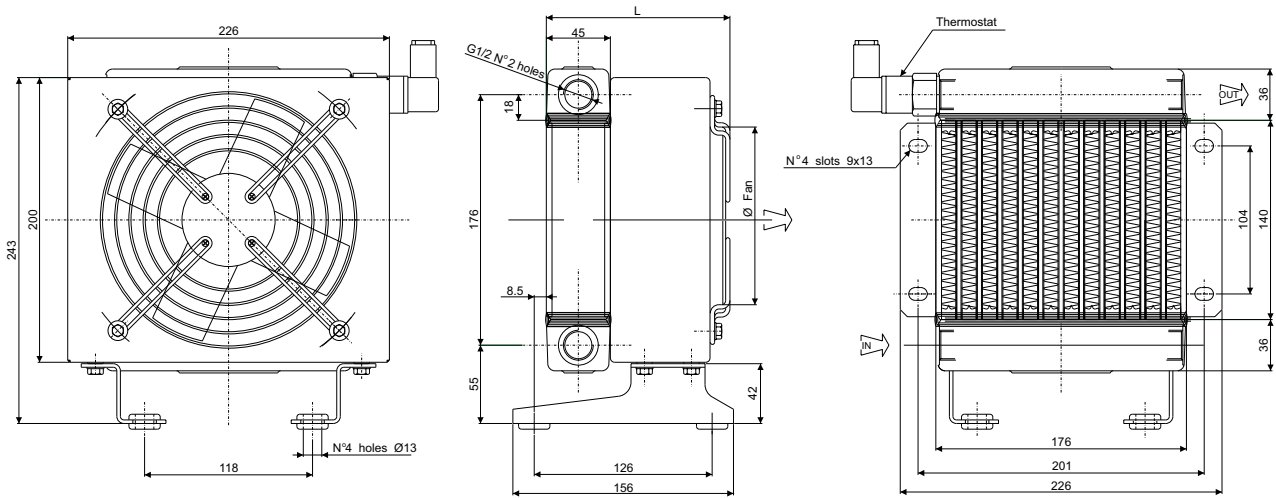

### Correction factor

CST	10	15	20	32	40	50	60	80	100	200
F	0.51	0.66	0.76	1	1.22	1.4	1.6	1.9	2.1	3.4

### Performance diagram

### Pressure drop diagram (32 cst)

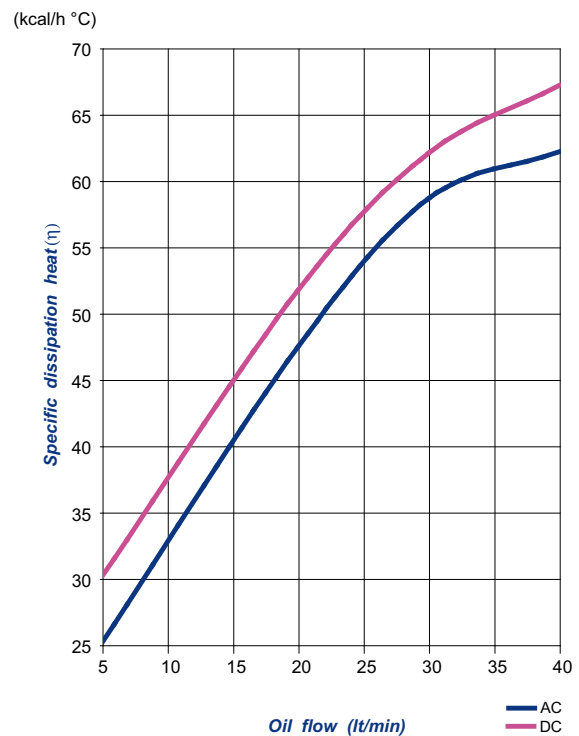
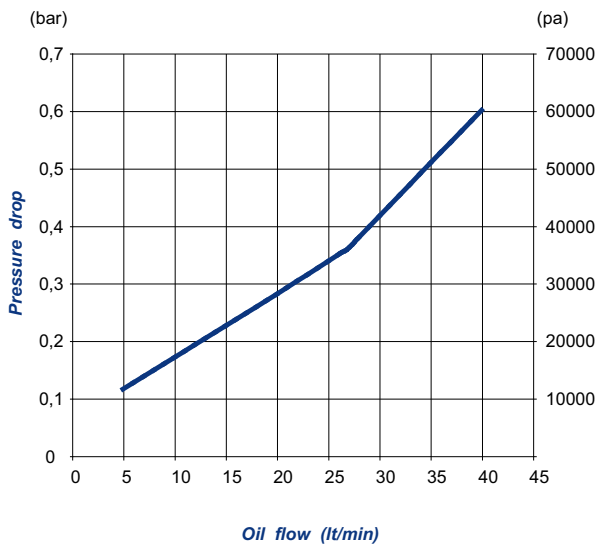

## SS Serie / Technische Daten

### SS Series / Technical features

Tipologia Type	Frequenza Frequency Hz	Tensione Voltage V	N° Giri/min RPM	Potenza Power kW	Diam. Ventola Ø FAN (mm)	dB (A)	L (mm)	Q air (m <sup>3</sup> /h)	Cap. (lt)	Peso Weight (kg)	IP
01	50	220	2500	0.055/0.060	200	52	170.5	715	0.48	7	54
03	50	380	2300	0.035/0.030	200	52	170.5	660	0.48	7	54
14	50	230/400	1350	0.25	200	67	347	700	0.48	10	55
	60	276/480	1620	0.30							
12	DC	12	3305	0.087	225	75	157	999	0.48	6.5	68
24	DC	24	3305	0.087	225	75	157	994	0.48	6.5	68
G2	-	-	-	-	200	-	200.5	-	0.48	6	-

Suggested oil flow from 20 to 80 (lt/min)

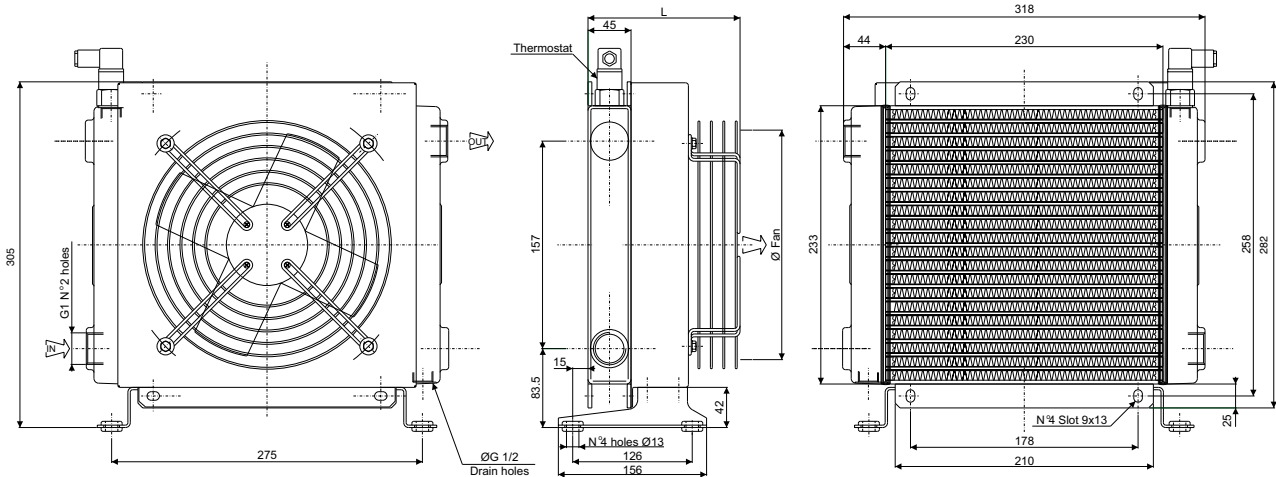

### Correction factor

CST	10	15	20	32	40	50	60	80	100	200
F	0.51	0.66	0.76	1	1.22	1.4	1.6	1.9	2.1	3.4

### Performance diagram

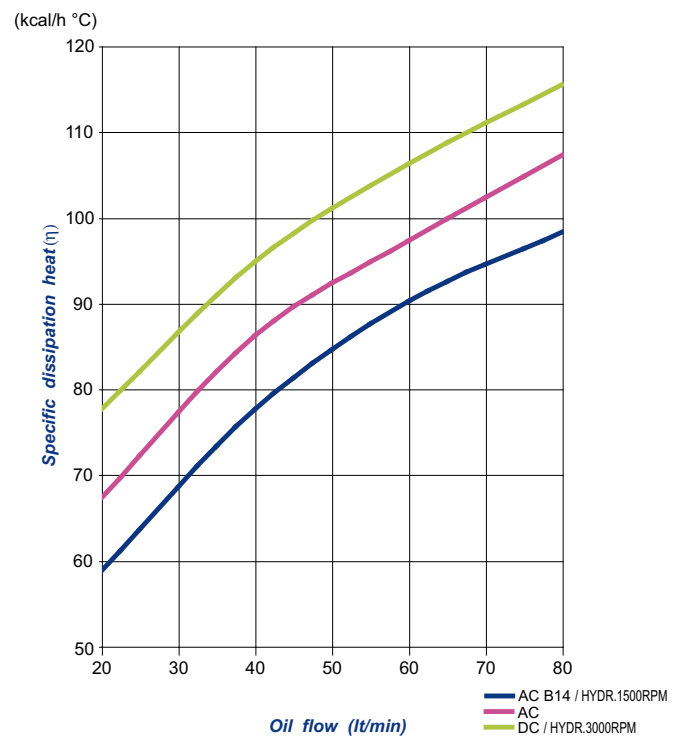

### Pressure drop diagram (32 cst)

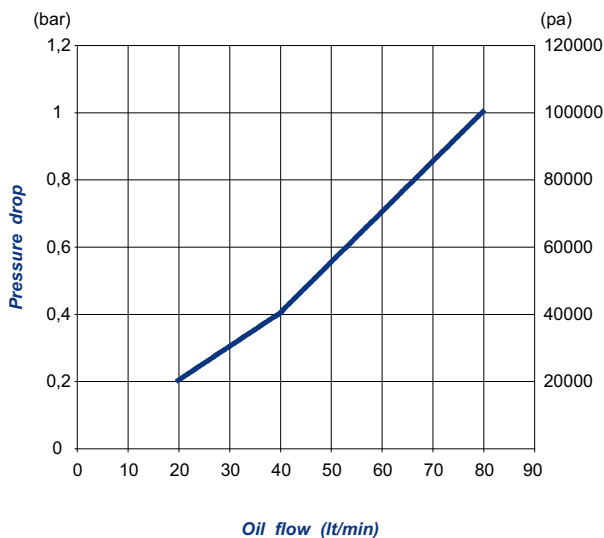

## SS Serie / Technische Daten

### SS Series / Technical features

Tipologia Type	Frequenza Frequency Hz	Tensione Voltage V	N° Giri/min RPM	Potenza Power kW	Diam. Ventola Ø FAN (mm)	dB (A)	L (mm)	Q air (m <sup>3</sup> /h)	Cap. (lt)	Peso Weight (kg)	IP
01	50/60	230	2500/2700	0.055/0.060	200	55	188.5	715	0.68	8	44
03	50/60	380	1400/1650	0.035/0.030	200	50	188.5	340	0.68	8	44
14	50	230/400	1350	0.25	200	67	365	700	0.68	11	55
	60	276/480	1620	0.30							
12	DC	12	3305	0.087	225	75	175	999	0.68	7	68
24	DC	24	3305	0.087	225	75	175	994	0.68	7	68
G2	-	-	-	-	200	-	218.5	-	0.68	7	-

Suggested oil flow from 30 to 100 (lt/min)

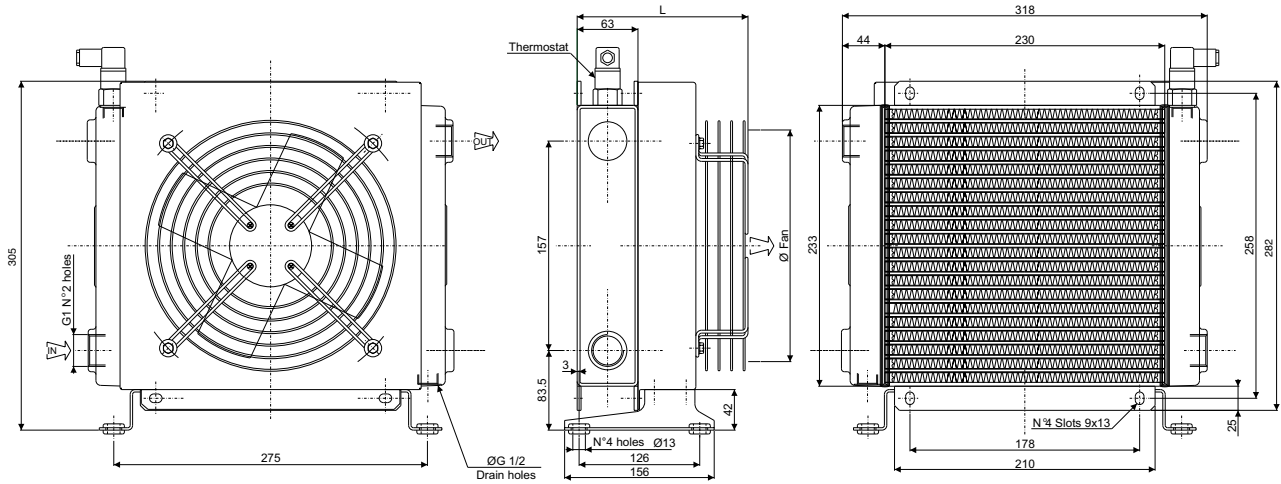

### Correction factor

CST	10	15	20	32	40	50	60	80	100	200
F	0.51	0.66	0.76	1	1.22	1.4	1.6	1.9	2.1	3.4

### Performance diagram

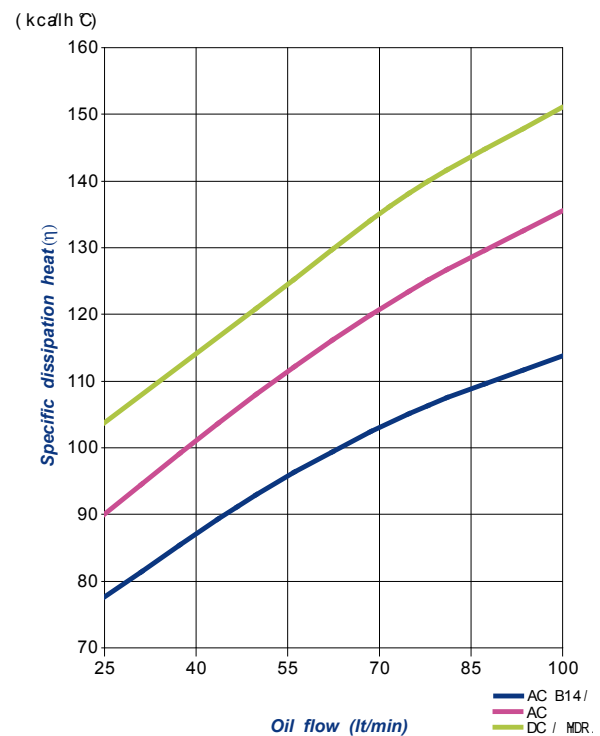

### Pressure drop diagram (32 cst)

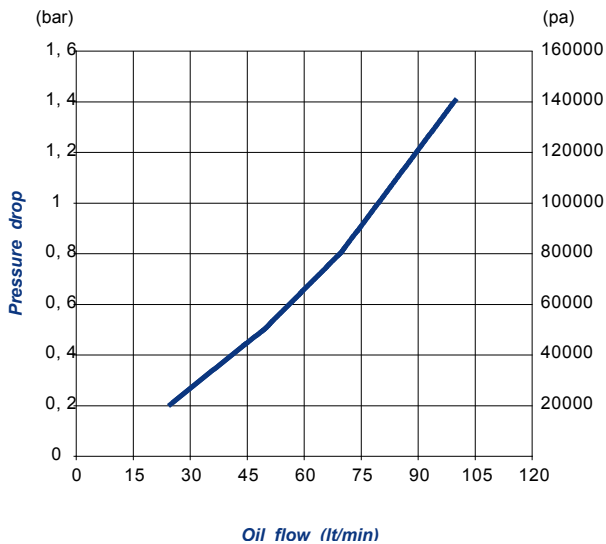

## SS Serie / Technische Daten

### SS Series / Technical features

Tipologia Type	Frequenza Frequency Hz	Tensione Voltage V	N° Giri/min RPM	Potenza Power kW	Diam. Ventola Ø FAN (mm)	dB (A)	L (mm)	Q air (m³/h)	Cap. (lt)	Peso Weight (kg)	IP
01	50	220	2400	0.080/0.090	250	60	178	1310	0.9	11	54
03	50	380	2400	0.055/0.052	250	60	178	1440	0.9	11	54
14	50 60	230/400 276/480	1350 1620	0.25 0.30	250	68	364	1500	0.9	15.5	55
12	DC	12	3005	0.106	280	74	175	1404	0.9	10	68
24	DC	24	3005	0.106	280	74	175	1477	0.9	10	68
G2	-	-	-	-	250	-	217.5	-	0.9	10	-

Suggested oil flow from 40 to 120 (lt/min)

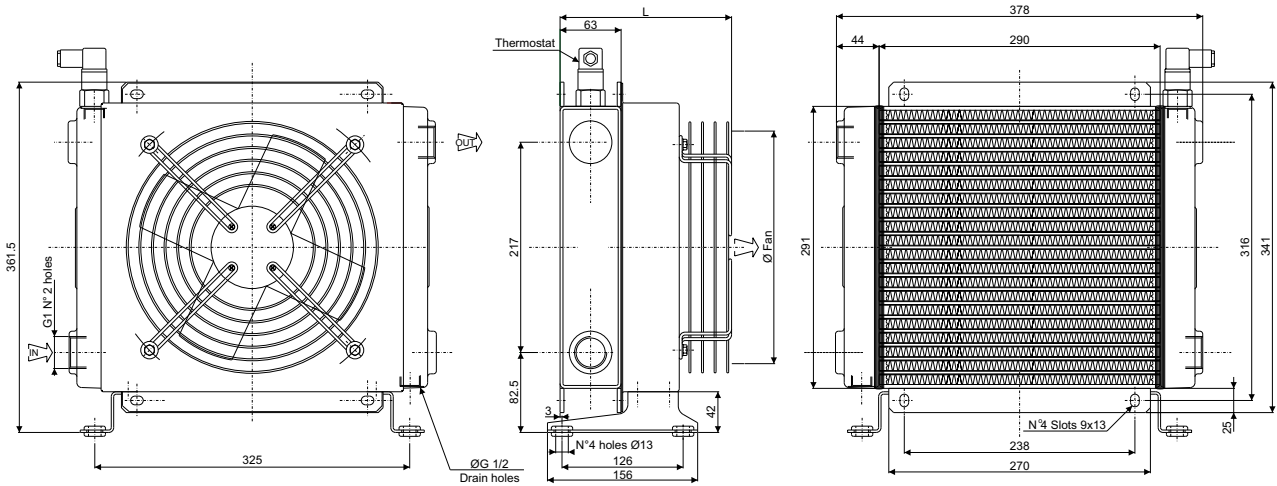

### Correction factor

CST	10	15	20	32	40	50	60	80	100	200
F	0.51	0.66	0.76	1	1.22	1.4	1.6	1.9	2.1	3.4

### Performance diagram

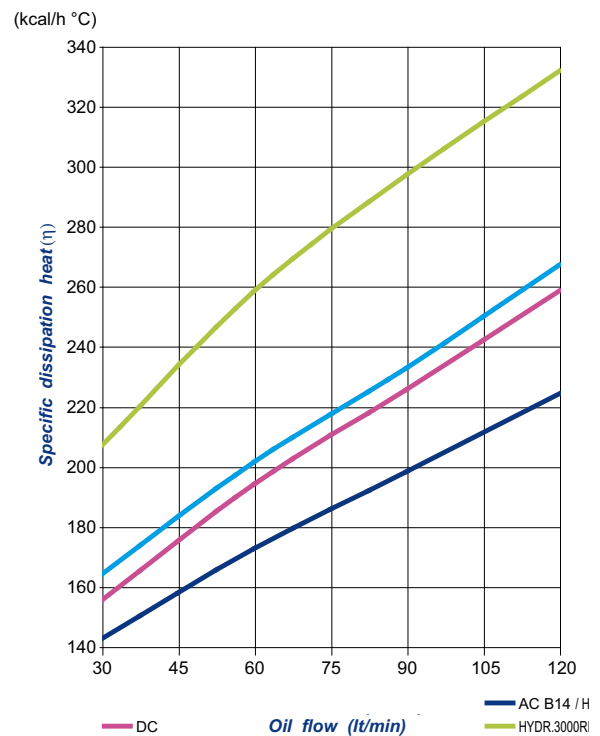

### Pressure drop diagram (32 cst)

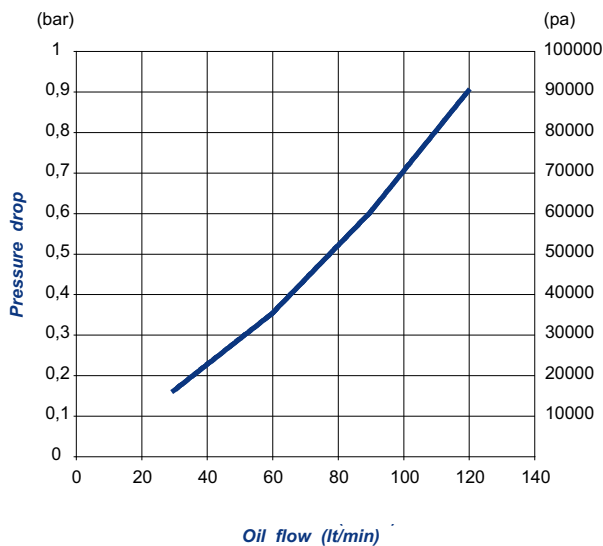



## SS Serie / Technische Daten

### SS Series / Technical features

Tipologia Type	Frequenza Frequency Hz	Tensione Voltage V	N° Giri/min RPM	Potenza Power kW	Diam. Ventola Ø FAN (mm)	dB (A)	L (mm)	Q air (m³/h)	Cap. (lt)	Peso Weight (kg)	IP
01	50	220	2300	0.145/0.175	300	62	213	2200	1.5	15	54
03	50	380	2340	0.075/0.095	300	62	213	1910	1.5	15	54
14	50 60	230/400 276/480	1370 1640	0.37 0.44	300	69	408	2000	1.5	20	55
12	DC	12	3090	0.218	305	82	217	2617	1.5	14	68
24	DC	24	3090	0.218	305	82	217	2324	1.5	14	68
G2	-	-	-	-	300	-	226.5	-	1.5	14.5	-

Suggested oil flow from 35 to 140 (lt/min)

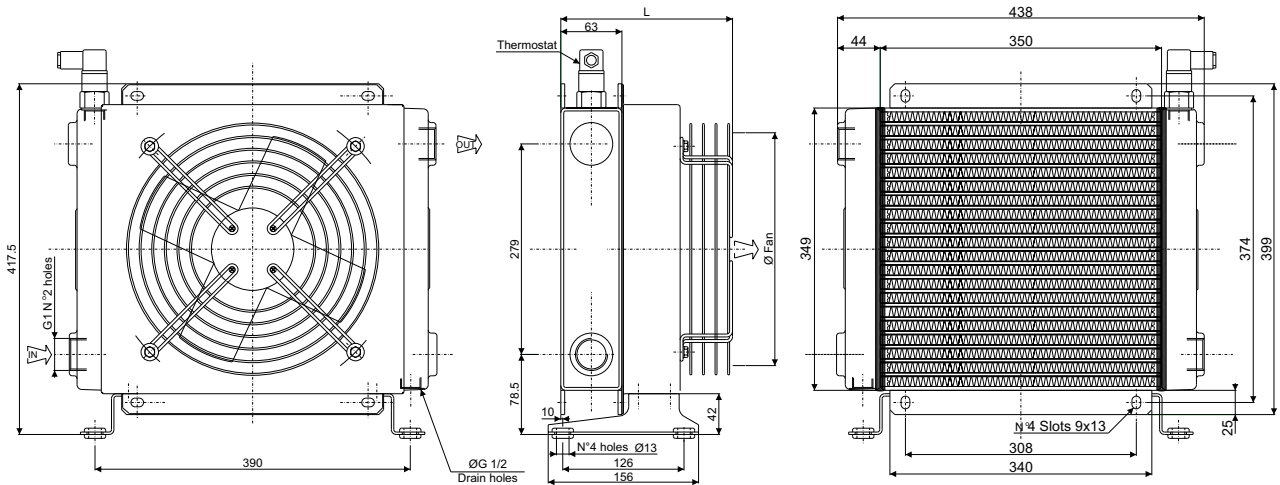

### Correction factor

CST	10	15	20	32	40	50	60	80	100	200
F	0.51	0.66	0.76	1	1.22	1.4	1.6	1.9	2.1	3.4

### Performance diagram

### Pressure drop diagram (32 cst)

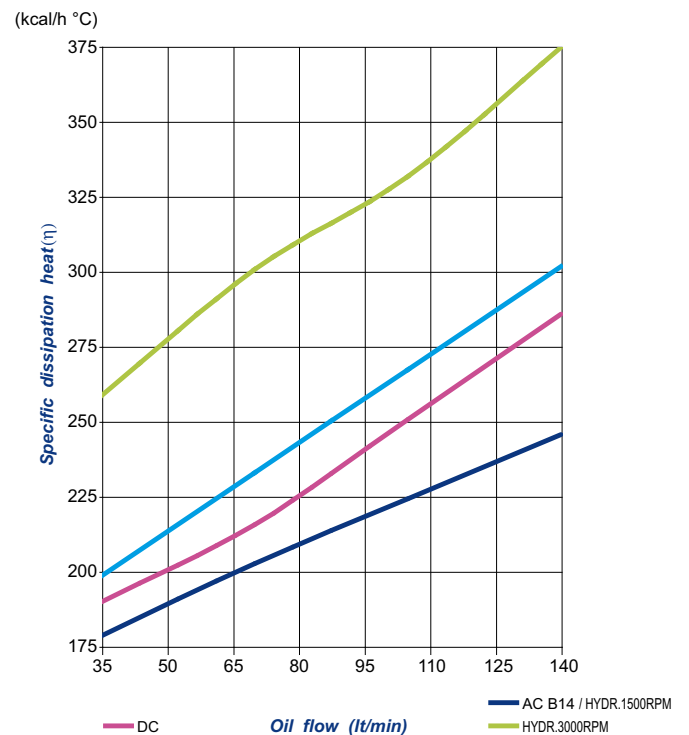
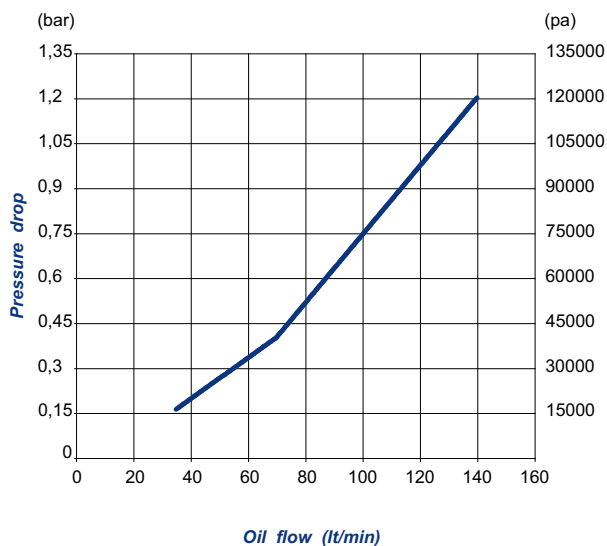

## SS Serie / Technische Daten

### SS Series / Technical features

Tipologia Type	Frequenza Frequency Hz	Tensione Voltage V	N° Giri/min RPM	Potenza Power kW	Diam. Ventola Ø FAN (mm)	dB (A)	L (mm)	Q air (m³/h)	Cap. (lt)	Peso Weight (kg)	IP
01	50/60	230	1380/1550	0.18/0.25	400	62	233	4000	2.6	21	44
03	50/60	380	1380/1520	0.18/0.25	400	70	233	4375	2.6	21	44
14	50 60	230/400 276/480	1390 1685	0.55 0.66	400	71	438	4000	2.6	25	55
12	DC	12	2248	0.151	385	77	206	2950	2.6	20	68
24	DC	24	2248	0.151	385	77	206	3101	2.6	20	68
G2	-	-	-	-	400	-	235.5	-	2.6	19	-

Suggested oil flow from 40 to 160 (lt/min)

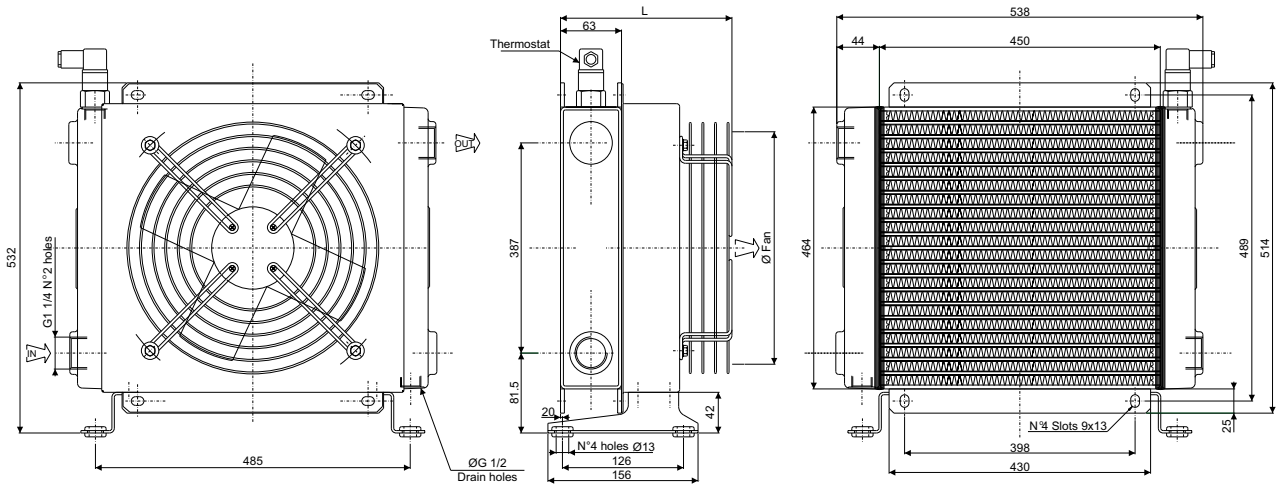

### Correction factor

CST	10	15	20	32	40	50	60	80	100	200
F	0.51	0.66	0.76	1	1.22	1.4	1.6	1.9	2.1	3.4

### Pressure drop diagram (32 cst)

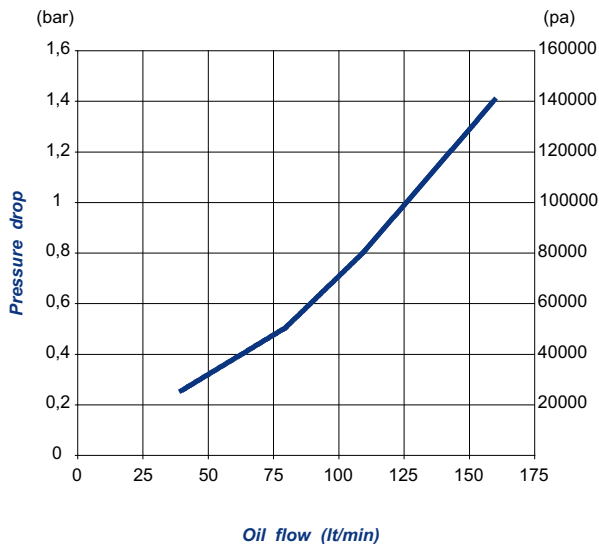

### Performance diagram

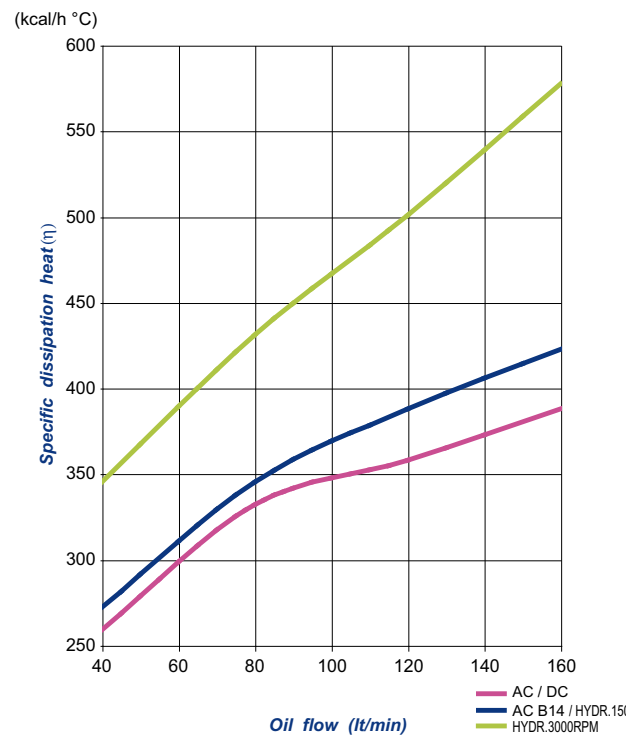

# SS Serie / Technische Daten

## SS Series / Technical features

Tipologia Type	Frequenza Frequency Hz	Tensione Voltage V	N° Giri/min RPM	Potenza Power kW	Diam. Ventola Ø FAN (mm)	dB (A)	L (mm)	Q air (m³/h)	Cap. (lt)	Peso Weight (kg)	IP
03	50/60	230/400	1380/1540	0.2/0.28	450	75	183	6040	4.9	27	44
14	50 60	230/400 276/480	1390 1685	0.75 0.90	450	73	445	6830	4.9	30	55
12	DC	12	3005	0.106 x 2	280	74	237,5	4200	4.9	24	68
24	DC	24	3005	0.106 x 2	280	74	237.5	4200	4.9	24	68
G2	-	-	-	-	450	-	243.5	-	4.9	23	-

Suggested oil flow from 50 to 180 (lt/min)

(x2) = double engine

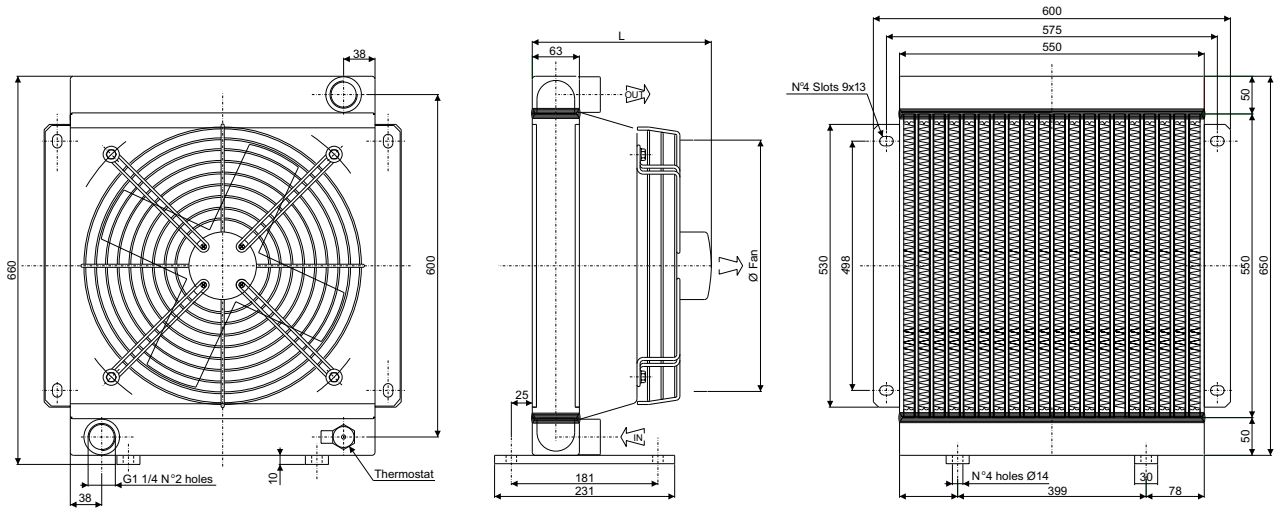

### Correction factor

CST	10	15	20	32	40	50	60	80	100	200
F	0.51	0.66	0.76	1	1.22	1.4	1.6	1.9	2.1	3.4

### Performance diagram

### Pressure drop diagram (32 cst)

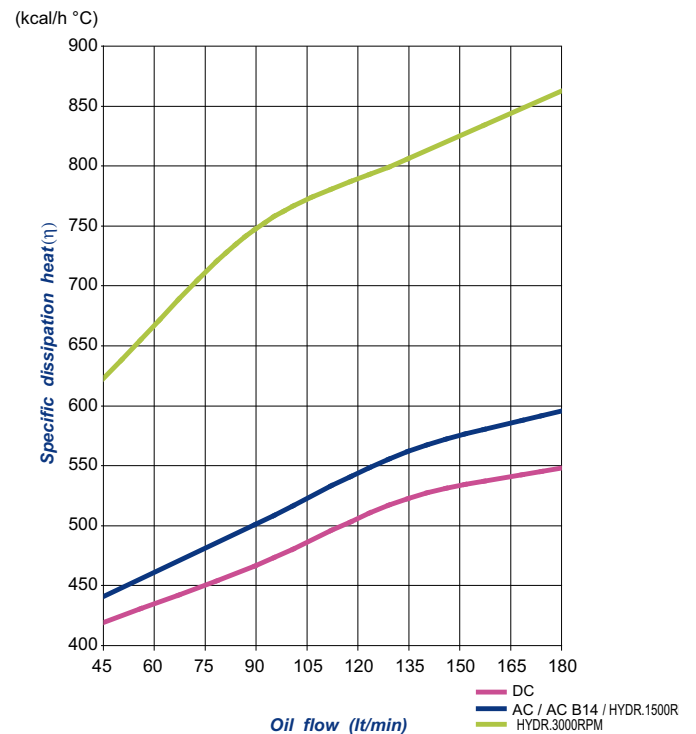
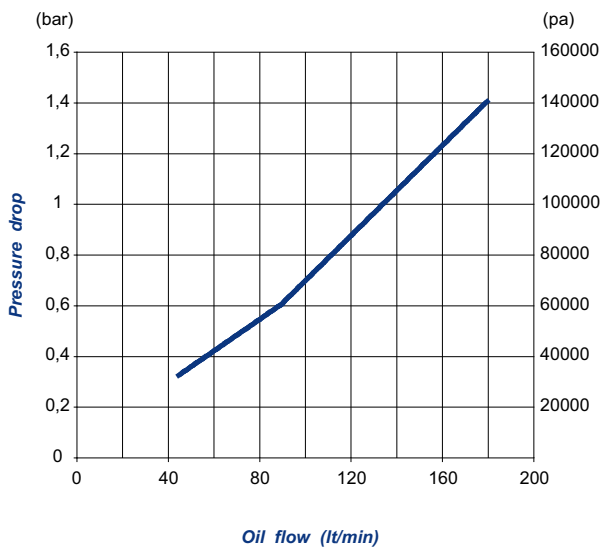

## SS Serie / Technische Daten

## SS Series / Technical features

Tipologia Type	Frequenza Frequency Hz	Tensione Voltage V	N° Giri/min RPM	Potenza Power kW	Diam. Ventola Ø FAN (mm)	dB (A)	L (mm)	Q air (m³/h)	Cap. (lt)	Peso Weight (kg)	IP
01	50/60	230	2500/2700	0.055/0.060	200	55	188.5	715	0.48	7	44
03	50/60	380	1400/1650	0.035/0.030	200	50	188.5	340	0.48	7	44
14	50 60	230/400 276/480	1350 1620	0.25 0.30	200	67	347	700	0.48	10	55
12	DC	12	3305	0.087	225	75	175	999	0.48	6.5	68
24	DC	24	3305	0.087	225	75	175	994	0.48	6.5	68
G2	-	-	-	-	200	-	200.5	-	0.48	6	-

Suggested oil flow from 5 to 40 (lt/min)

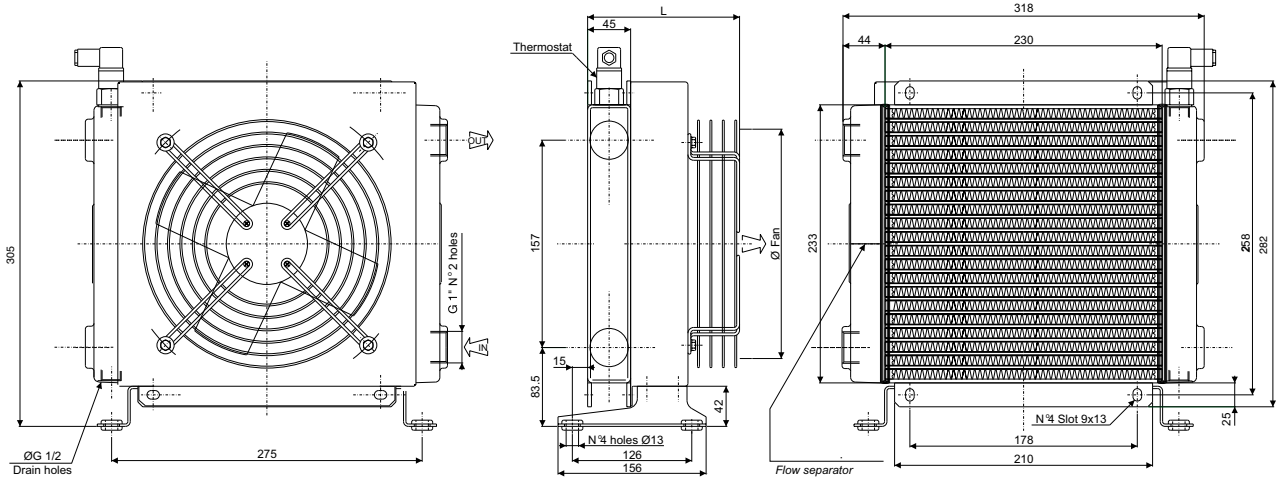

### Correction factor

CST	10	15	20	32	40	50	60	80	100	200
F	0.51	0.66	0.76	1	1.22	1.4	1.6	1.9	2.1	3.4

### Performance diagram

### Pressure drop diagram (32 cst)

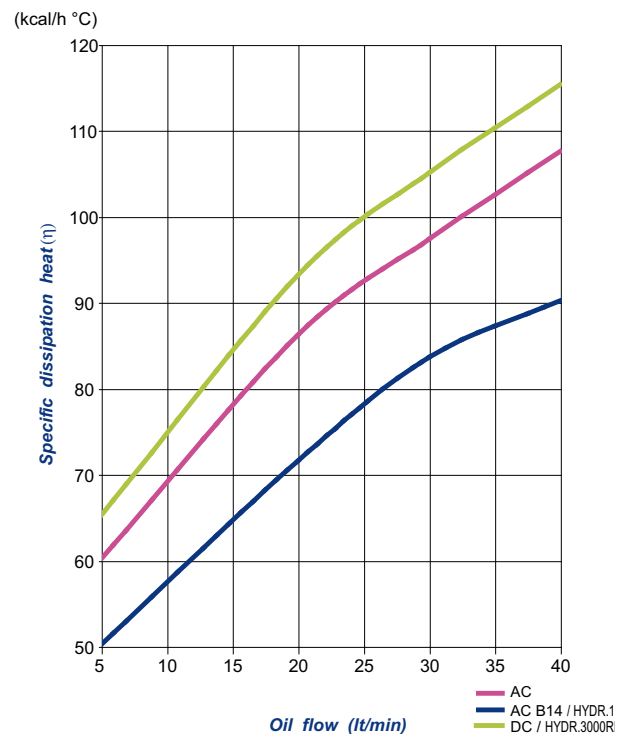
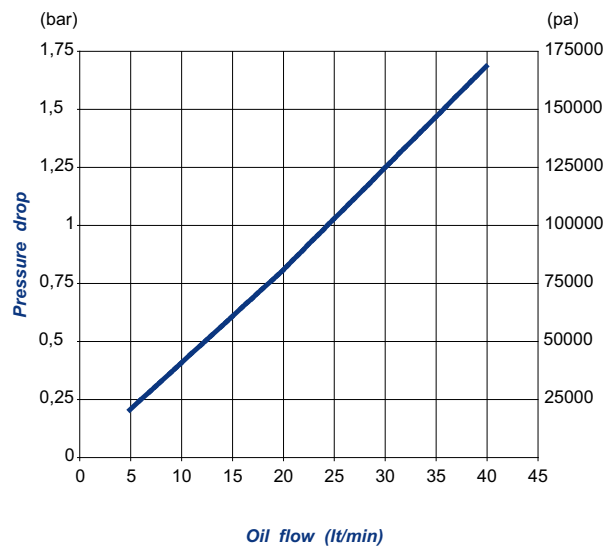

## SS Serie / Technische Daten

### SS Series / Technical features

Tipologia Type	Frequenza Frequency Hz	Tensione Voltage V	N° Giri/min RPM	Potenza Power kW	Diam. Ventola Ø FAN (mm)	dB (A)	L (mm)	Q air (m³/h)	Cap. (lt)	Peso Weight (kg)	IP
01	50/60	230	2500/2700	0.055/0.060	200	55	188.5	715	0.68	8	44
03	50/60	380	1400/1650	0.035/0.030	200	50	188.5	340	0.68	8	44
14	50	230/400	1350	0.25	200	67	365	700	0.68	11	55
	60	276/480	1620	0.30							
12	DC	12	3305	0.087	225	75	175	999	0.68	7	68
24	DC	24	3305	0.087	225	75	175	994	0.68	7	68
G2	-	-	-	-	200	-	218.5	-	0.68	7	-

Suggested oil flow from 5 to 40 (lt/min)

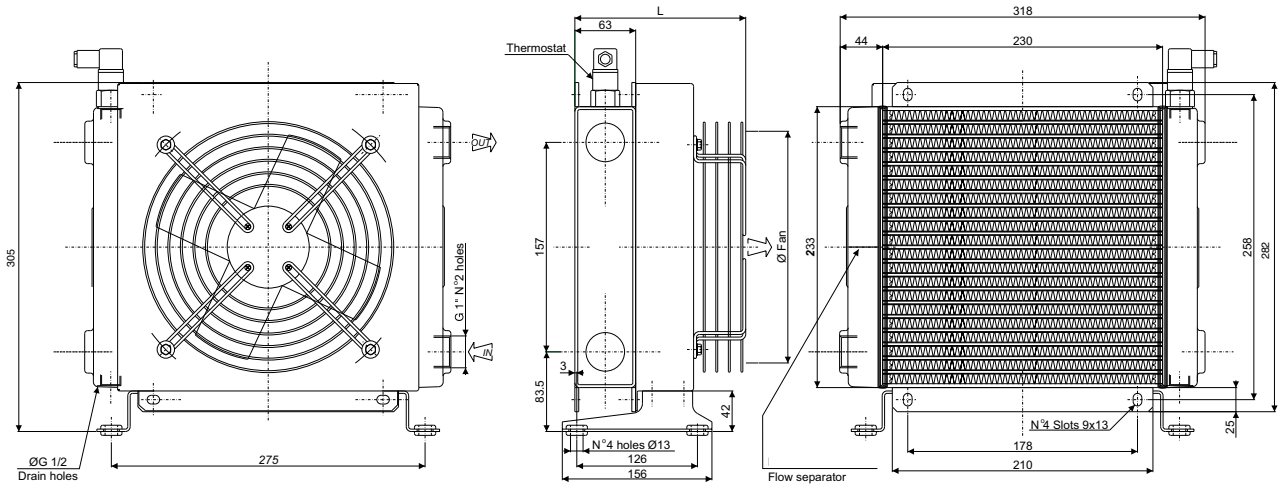

### Correction factor

CST	10	15	20	32	40	50	60	80	100	200
F	0.51	0.66	0.76	1	1.22	1.4	1.6	1.9	2.1	3.4

### Performance diagram

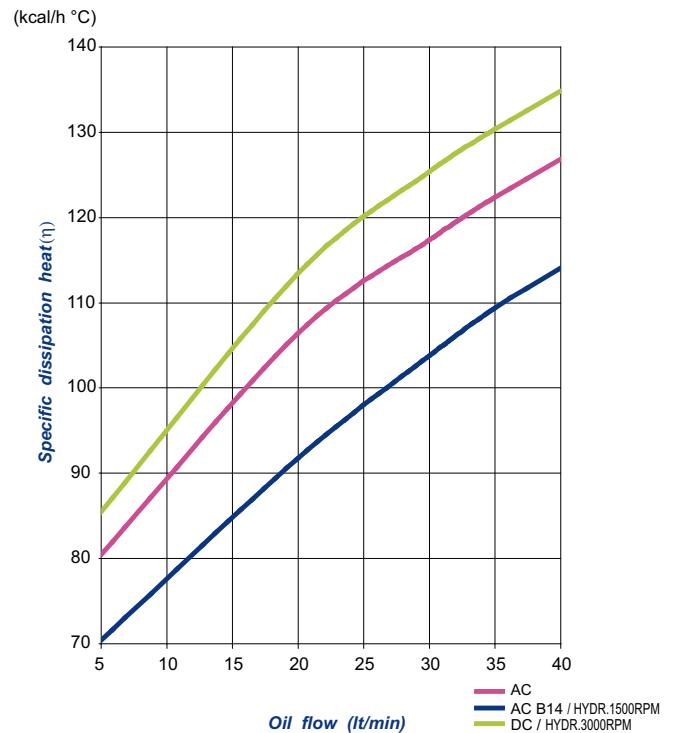

### Pressure drop diagram (32 cst)

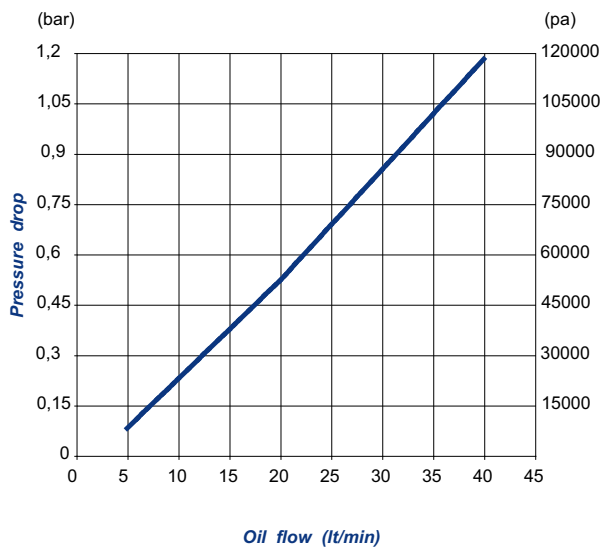

## SS Serie / Technische Daten

### SS Series / Technical features

Tipologia Type	Frequenza Frequency Hz	Tensione Voltage V	N° Giri/min RPM	Potenza Power kW	Diam. Ventola Ø FAN (mm)	dB (A)	L (mm)	Q air (m³/h)	Cap. (lt)	Peso Weight (kg)	IP
01	50	220	2400	0.080/0.090	250	60	178	1310	0.9	11	54
03	50	380	2400	0.055/0.030	250	60	178	1440	0.9	11	54
14	50 60	230/400 276/480	1350 1620	0.25 0.30	250	67	364	1500	0.9	15,5	55
12	DC	12	3005	0.106	280	74	175	1404	0.9	10	68
24	DC	24	3005	0.106	280	74	175	1477	0.9	10	68
G2	-	-	-	-	250	-	217.5	-	0.9	10	-

Suggested oil flow from 10 to 60 (lt/min)

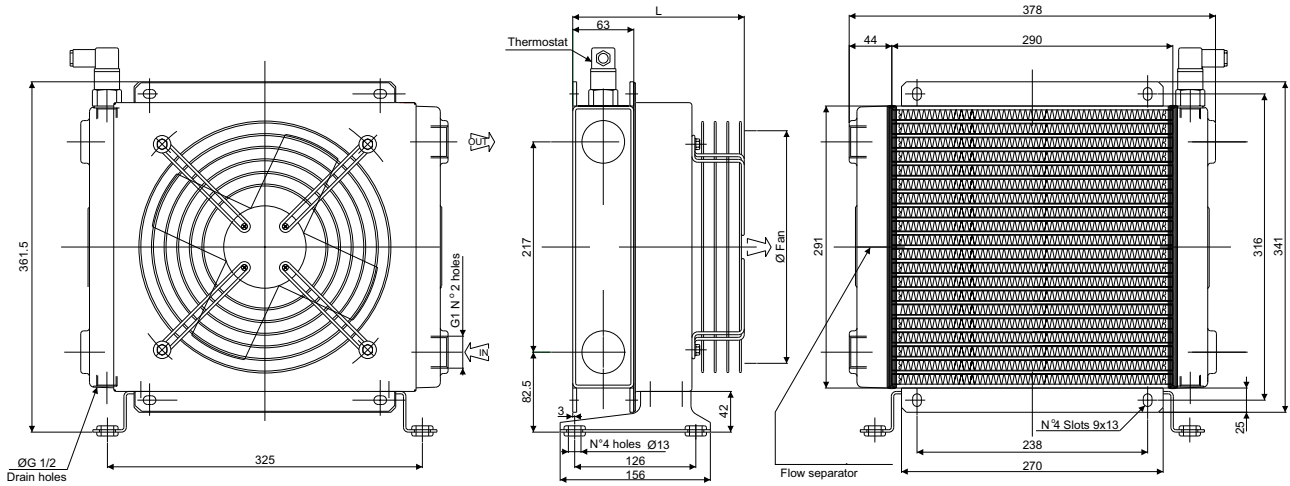

### Correction factor

CST	10	15	20	32	40	50	60	80	100	200
F	0.51	0.66	0.76	1	1.22	1.4	1.6	1.9	2.1	3.4

### Performance diagram

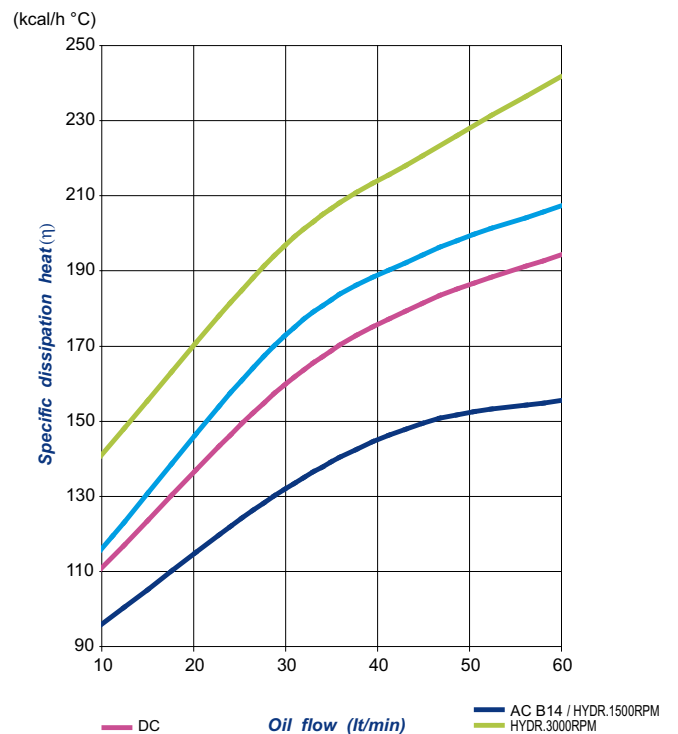

### Pressure drop diagram (32 cst)

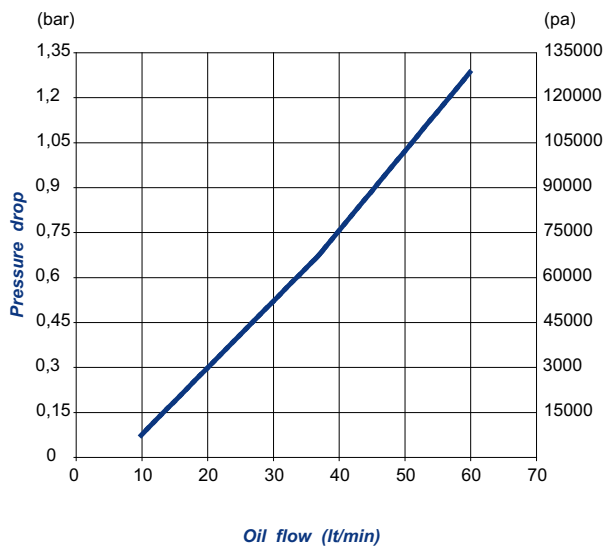

## SS Serie / Technische Daten

### SS Series / Technical features

Tipologia Type	Frequenza Frequency Hz	Tensione Voltage V	N° Giri/min RPM	Potenza Power kW	Diam. Ventola Ø FAN (mm)	dB (A)	L (mm)	Q air (m³/h)	Cap. (lt)	Peso Weight (kg)	IP
01	50	220	2300	0.145/0.175	300	62	213	2200	1.5	15	54
03	50	380	2340	0.075/0.095	300	62	213	1910	1.5	15	54
14	50 60	230/400 276/480	1370 1640	0.37 0.44	300	69	408	2000	1.5	20	55
12	DC	12	3090	0.218	305	82	217	2616	1.5	14	68
24	DC	24	3090	0.218	305	82	217	2324	1.5	14	68
G2	-	-	-	-	300	-	226.5	-	1.5	14.5	-

Suggested oil flow from 15 to 60 (lt/min)

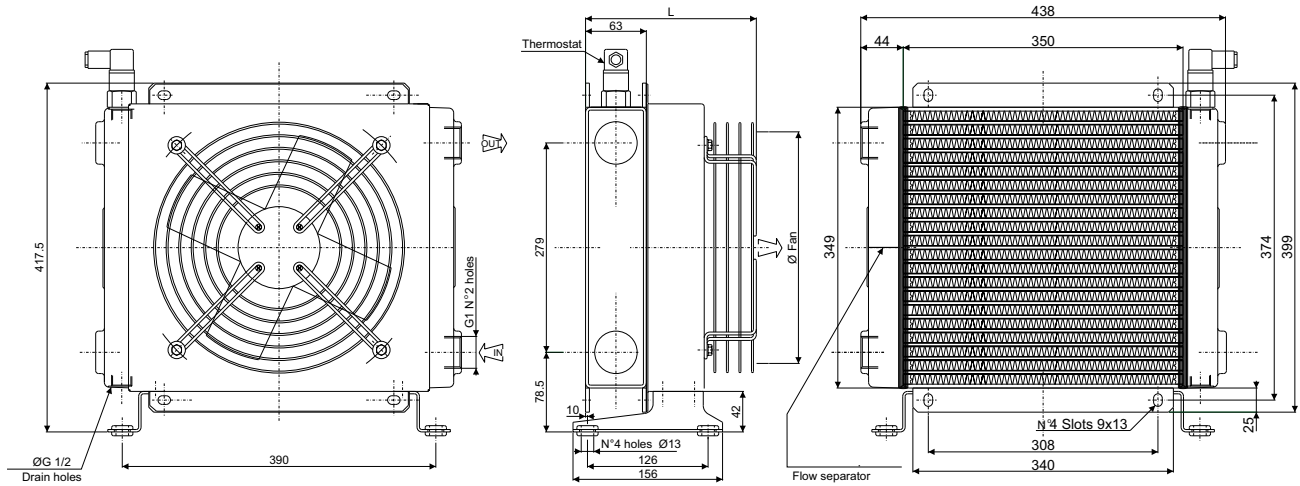

### Correction factor

CST	10	15	20	32	40	50	60	80	100	200
F	0.51	0.66	0.76	1	1.22	1.4	1.6	1.9	2.1	3.4

### Performance diagram

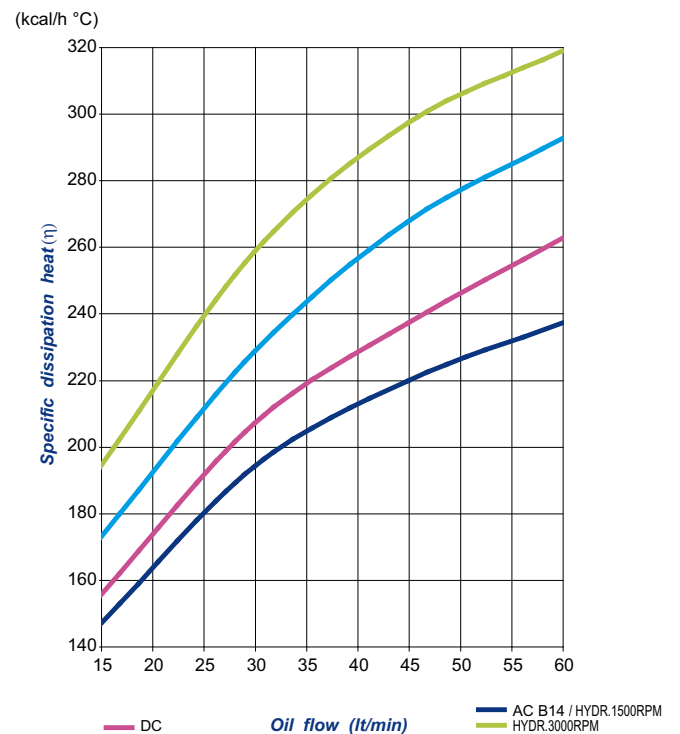

### Pressure drop diagram (32 cst)

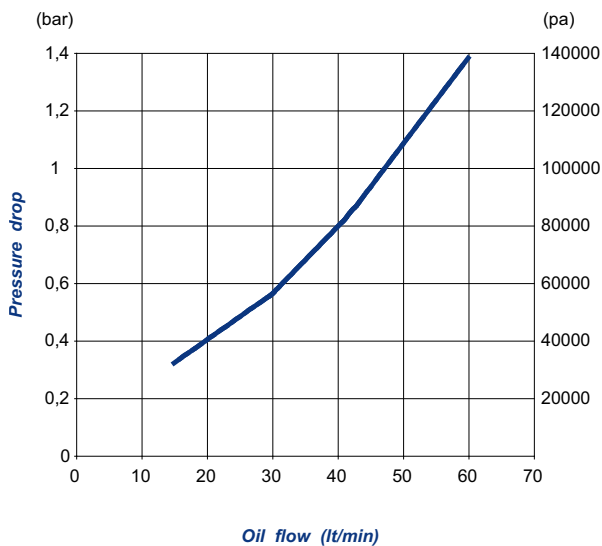

## SS Serie / Technische Daten

### SS Series / Technical features

Tipologia Type	Frequenza Frequency Hz	Tensione Voltage V	N° Giri/min RPM	Potenza Power kW	Diam. Ventola Ø FAN (mm)	dB (A)	L (mm)	Q air (m³/h)	Cap. (lt)	Peso Weight (kg)	IP
01	50/60	230	1380/1550	0.18/0.25	400	62	233	4000	2.6	21	44
03	50/60	380	1380/1520	0.18/0.25	400	70	233	4375	2.6	21	44
14	50 60	230/400 276/480	1390 1685	0.55 0.66	400	71	438	4000	2.6	25	55
12	DC	12	2248	0.151	385	77	206	2950	2.6	20	68
24	DC	24	2248	0.151	385	77	206	3101	2.6	20	68
G2	-	-	-	-	400	-	236.5	-	2.6	19	-

Suggested oil flow from 20 to 80 (lt/min)

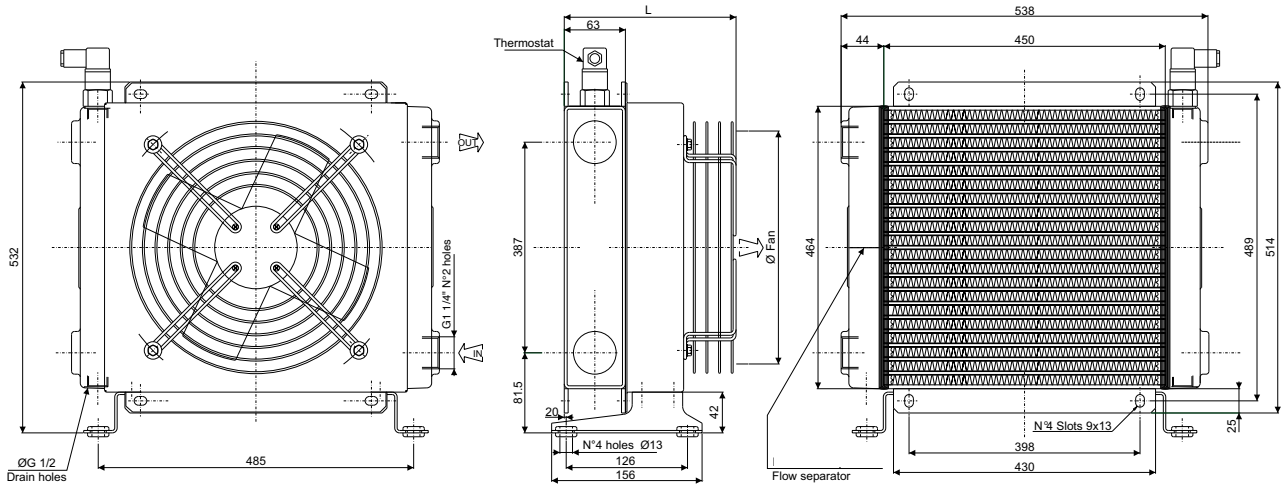

### Correction factor

CST	10	15	20	32	40	50	60	80	100	200
F	0.51	0.66	0.76	1	1.22	1.4	1.6	1.9	2.1	3.4

### Pressure drop diagram (32 cst)

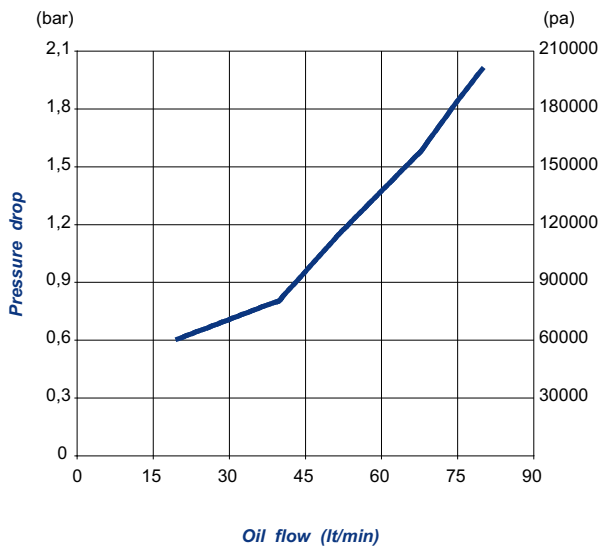

### Performance diagram

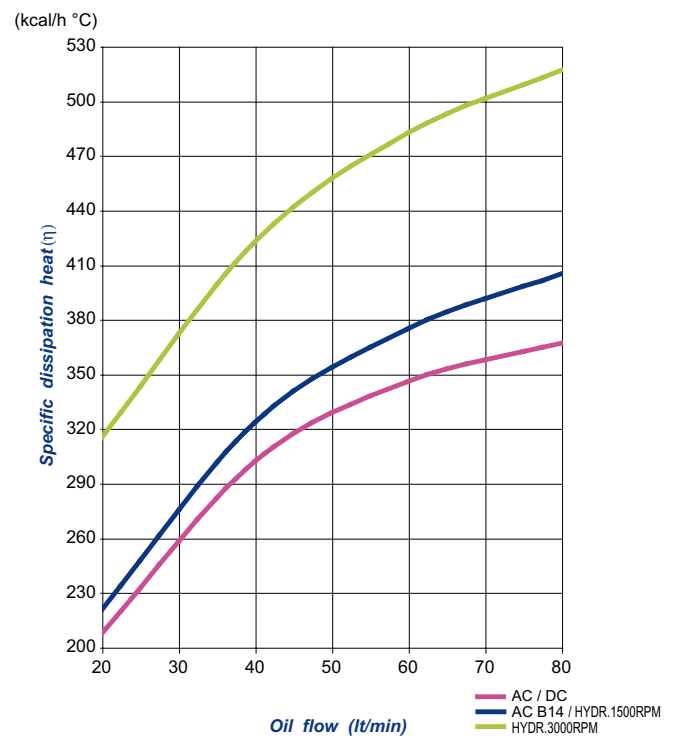



## SS Serie / Technische Daten

### SS Series / Technical features

Tipologia Type	Frequenza Frequency Hz	Tensione Voltage V	N° Giri/min RPM	Potenza Power kW	Diam. Ventola Ø FAN (mm)	dB (A)	L (mm)	Q air (m³/h)	Cap. (lt)	Peso Weight (kg)	IP
01	50	220	2500	0.055/0.060	200	52	188.5	1430	1.3	17	54
03	50	380	2300	0.035/0.030	200	52	188.5	1320	1.3	17	54
14	50 60	230/400 276/480	1350 1620	0.25 0.30	200	67	365	1400	1.3	23	55
12	DC	12	3305	0.087	225	75	175	1998	1.3	15	68
24	DC	24	3305	0.087	225	75	175	1988	1.3	15	68
G2	-	-	-	-	200	-	218.5	-	1.3	17	-

Suggested oil flow from 60 to 180 (lt/min)

(x2) = double engine

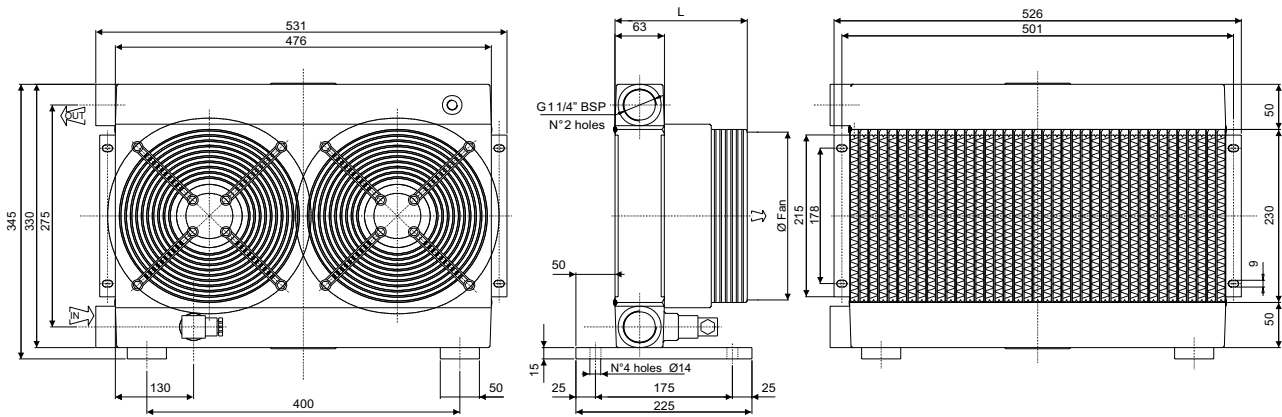

### Correction factor

CST	10	15	20	32	40	50	60	80	100	200
F	0.51	0.66	0.76	1	1.22	1.4	1.6	1.9	2.1	3.4

### Performance diagram

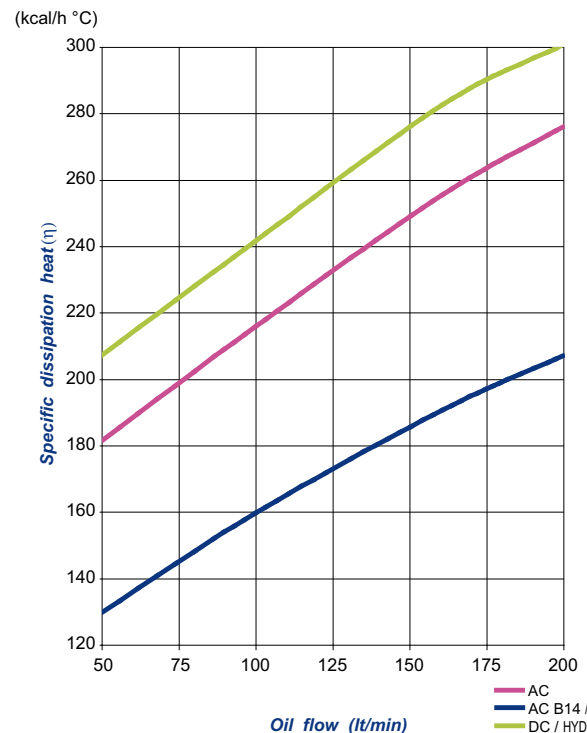

### Pressure drop diagram (32 cst)

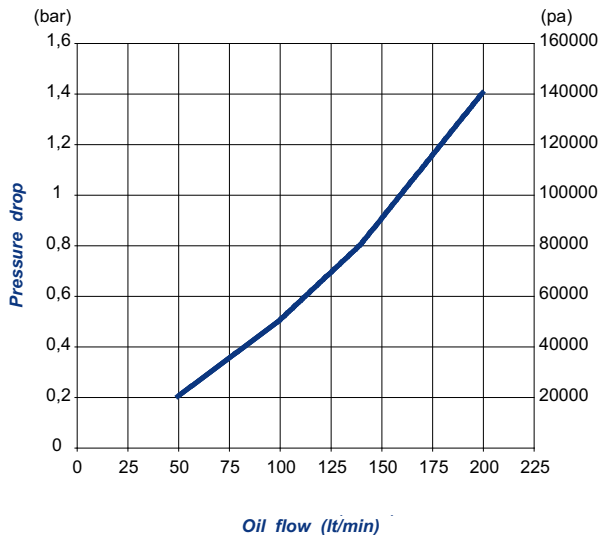

## SS Serie / Technische Daten

## SS Series / Technical features

Tipologia Type	Frequenza Frequency Hz	Tensione Voltage V	N° Giri/min RPM	Potenza Power kW	Diam. Ventola Ø FAN (mm)	dB (A)	L (mm)	Q air (m³/h)	Cap. (lt)	Peso Weight (kg)	IP
50	220	2400	2400/2750	0.080/0.090	60	62	178	2620	1.9	23	54
50	380	2400	1400/1650	0.055/0.052	60	58	178	2880	1.9	23	54
14	50	230/400	1350	0.25	250	68	364	3000	1.9	34	55
12	DC	12	3005	0.106	280	74	175	2808	1.9	21	68
24	DC	24	3005	0.106	280	74	175	2954	1.9	21	68
G2	-	-	-	-	250	-	217.5	-	1.9	23	-

Suggested oil flow from 80 to 220 (lt/min)

(x2) = double engine

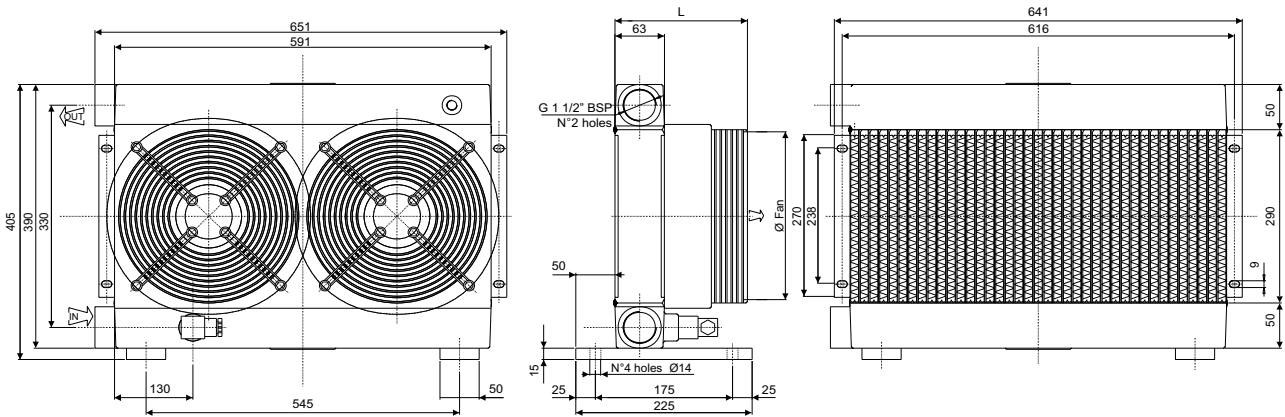

### Correction factor

CST	10	15	20	32	40	50	60	80	100	200
F	0.51	0.66	0.76	1	1.22	1.4	1.6	1.9	2.1	3.4

### Performance diagram

### Pressure drop diagram (32 cst)

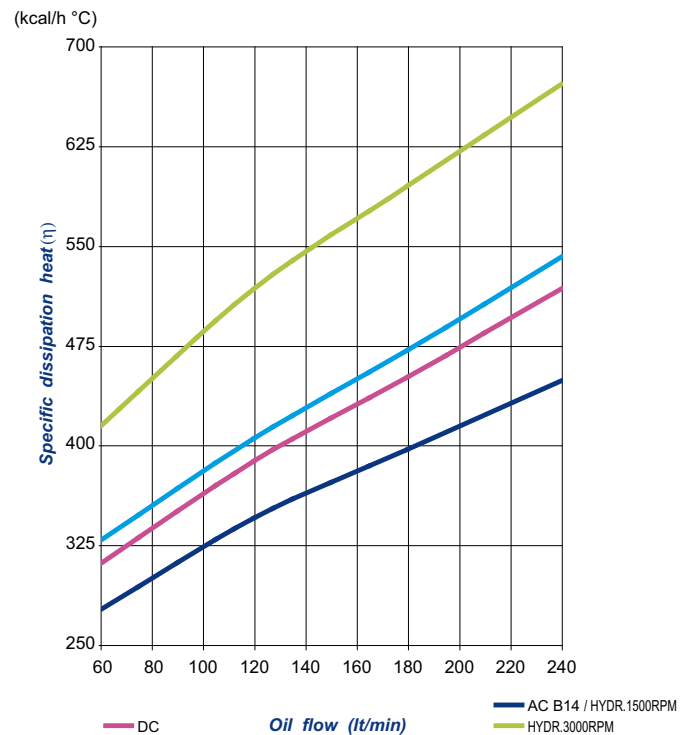
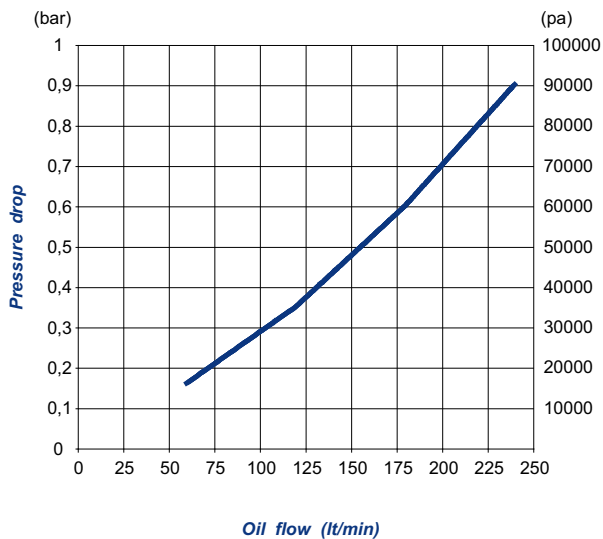

## SS Serie / Technische Daten

### SS Series / Technical features

Tipologia Type	Frequenza Frequency Hz	Tensione Voltage V	N° Giri/min RPM	Potenza Power kW	Diam. Ventola Ø FAN (mm)	dB (A)	L (mm)	Q air (m³/h)	Cap. (lt)	Peso Weight (kg)	IP
01	50	220	2300	0.145/0.175	300	62	213	4400	3.1	31	54
03	50	380	2340	0.075/0.095	300	62	213	3820	3.1	31	54
14	50 60	230/400 276/480	1370 1640	0.37 0.44	300	69	408	4000	3.1	42	55
12	DC	12	3090	0.218	305	82	217	5234	3.1	29	68
24	DC	24	3090	0.218	305	82	217	4648	3.1	29	68
G2	-	-	-	-	300	-	226.5	-	3.1	30	-

Suggested oil flow from 80 to 260 (lt/min)

(x2) = double engine

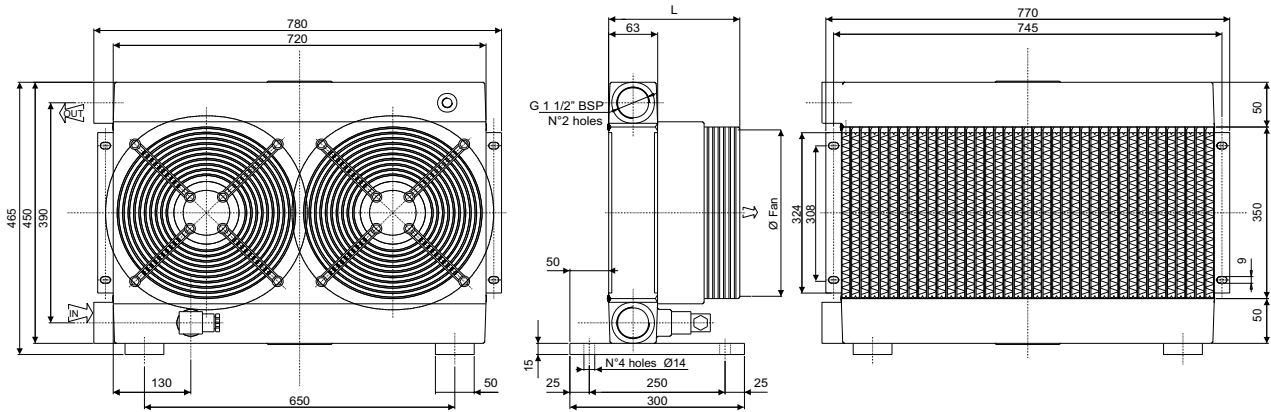

### Correction factor

CST	10	15	20	32	40	50	60	80	100	200
F	0.51	0.66	0.76	1	1.22	1.4	1.6	1.9	2.1	3.4

### Performance diagram

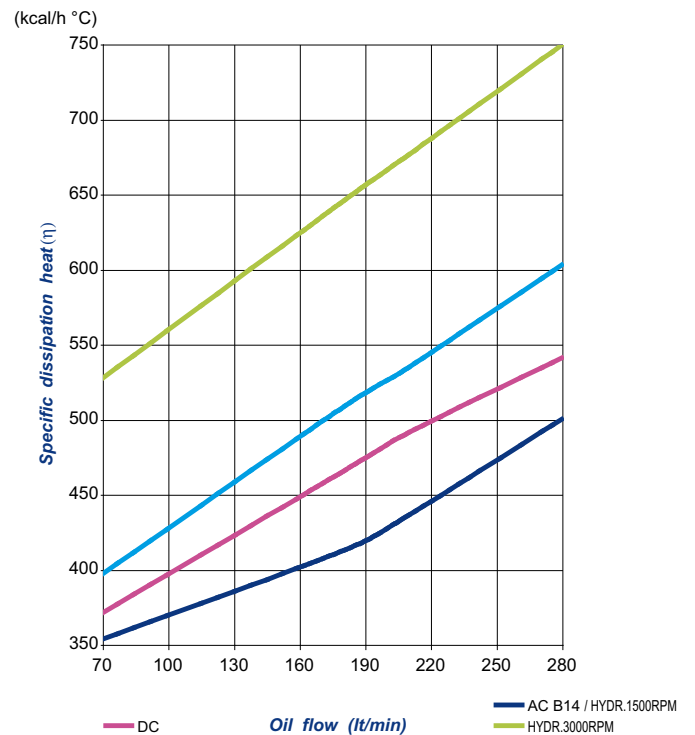

### Pressure drop diagram (32 cst)

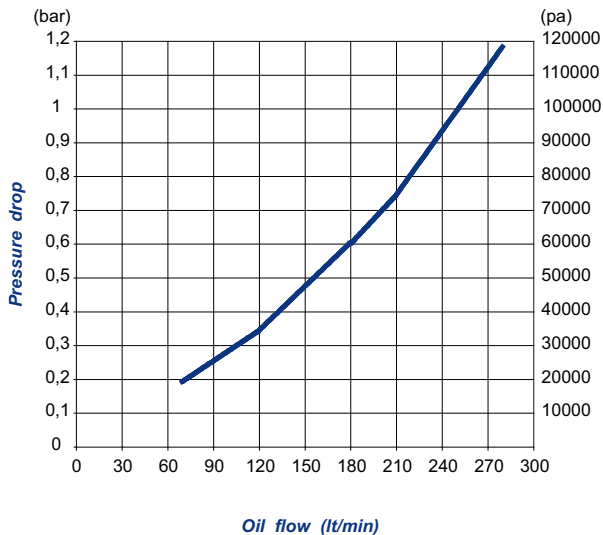

# SS Serie / Technische Daten

## SS Series / Technical features

Tipologia Type	Frequenza Frequency Hz	Tensione Voltage V	N° Giri/min RPM	Potenza Power kW	Diam. Ventola Ø FAN (mm)	dB (A)	L (mm)	Q air (m³/h)	Cap. (lt)	Peso Weight (kg)	IP
01	50/60	230	1380/1550	0.18/0.25	400	62	233	8000	5.3	42	44
03	50/60	380	1380/1520	0.18/0.25	400	70	233	8750	5.3	42	44
14	50 60	230/400 276/480	1390 1685	0.55 0.66	400	71	438	8000	5.3	50	55
12	DC	12	2248	0.151	385	77	206	5900	5.3	41	68
24	DC	24	2248	0.151	385	77	206	6202	5.3	41	68
G2	-	-	-	-	400	-	236.5	-	5.3	39	-

Suggested oil flow from 80 to 300 (lt/min)

(x2) = double engine

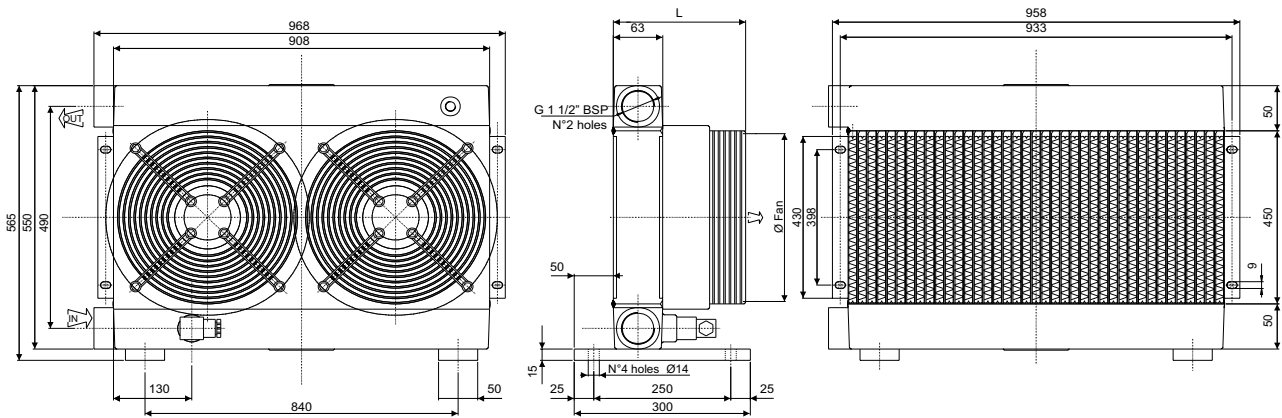

### Correction factor

CST	10	15	20	32	40	50	60	80	100	200
F	0.51	0.66	0.76	1	1.22	1.4	1.6	1.9	2.1	3.4

### Performance diagram

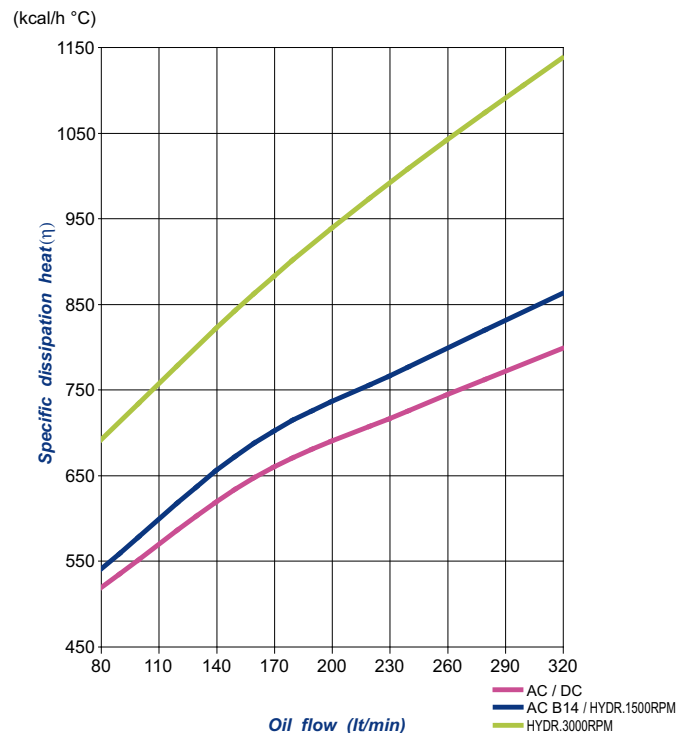

### Pressure drop diagram (32 cst)

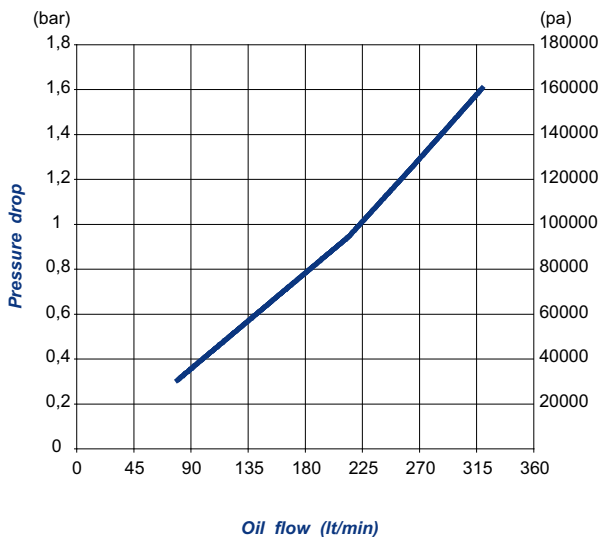

## SS Serie / Bimetallischer Festtemperaturschalter

### SS Series / Bimetallic fixed temperature switch

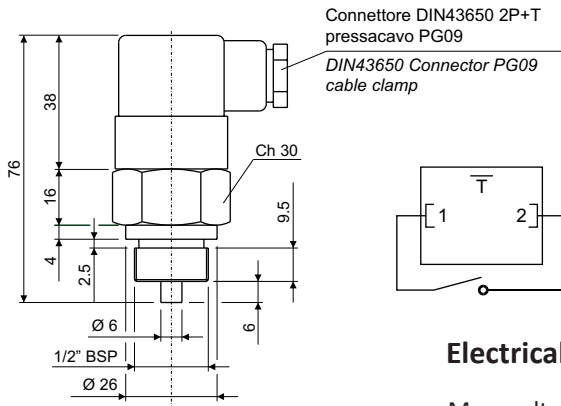

Note: Assemble switch to the heat exchanger with a copper flat washer

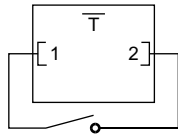

Switch part number	Working temperature	Contact
T01	36-26°C	
T02	43-33°C	
T03	52-42°C	
T04	65-55°C	NA/NO
T05	75-65°C	
T06	85-75°C	
T07	95-85°C	

NO = normally open

#### Electrical data

Max. voltage	250Vca
Max. current	10A
Tolerance	±5°C
Max. fixed hysteresis	15°C
Electrical connection	DIN43650
Protection degree	IP65
Max. temperature	130°C

#### Materials

Body	Brass
Contacts	Silver plated

#### Temperature switch

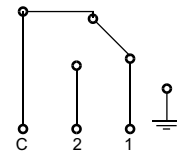
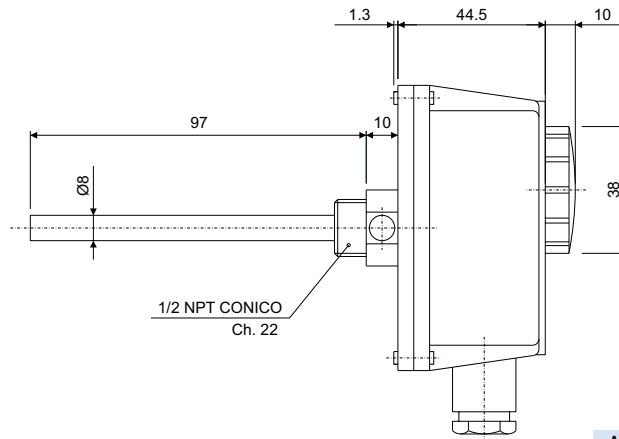
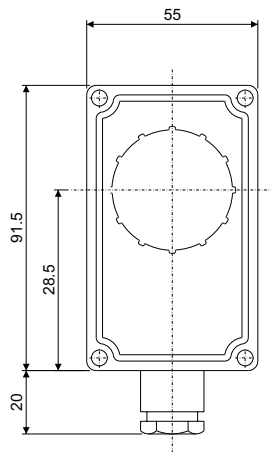

Adjustable switch part number

T08

#### Electrical data

Temperature range	0°±90°C
Tolerance	±5k
Temperature differential	6±2k
Degree of protection	IP 40
Insulation class	I
Temp. rate of change	<1k/min
Max. head temperature	80°C
Max. sensing bulb temp.	125°C
Storage temperature	-15°C 55°C
Time constant	<1'
Contacts rating	C-1:10(2.5)A/250V~ C-2:6(2.5)A/250V~
Output	cutoff or switching contacts
Switch action	1B
Installation location	normal environment
Fairlead type	M20x1.5

## SS Serie / Zubehör

### SS Series / Accessories

#### Temperature switch with integrated relay

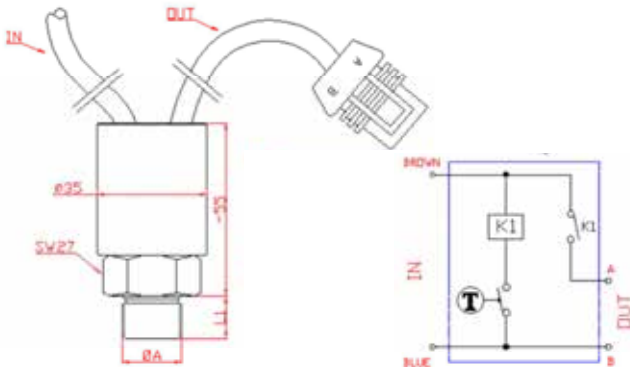

#### Electrical data

Electrical rating  
Fluid temperature range  
Electrical contact  
Electrical configuration  
Protection degree  
Intervention tolerance  
Hysteresis

30 @ 12VDC / 30 @ 24VDC  
-30/+130 °C (-22/+266°F)  
Silver plated  
Normal open  
Standard IP67  
±4,5 °C  
~15 °C

Switch part number	A	Description
T10	1/2" BSP	70-60 24V
T11		60-50 24V
T12		50-40 24V
T13		70-60 12V
T14		60-50 12V
T15		50-40 12V

Temperature switch with relay

#### Standard connector



#### Optional

KIT-WPC-M



#### Electronic Thermostat with integrated soft starter control for direct currents loads

Cable electrical connection. Logic ON/OFF control 12 ÷ 24VDC / 20A

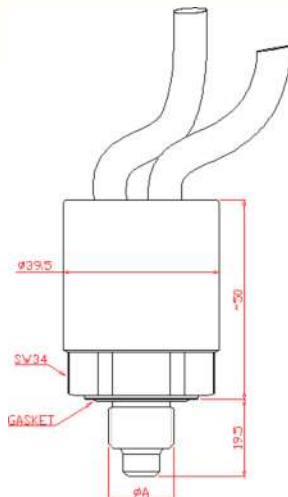

Timing diagram

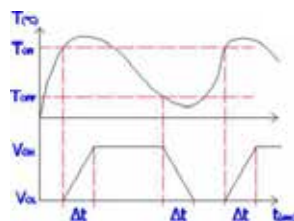

#### Electrical data

Electrical configuration  
Supply voltage  
Maximum load  
Electrical protection  
Environmental temperature  
Stocking temperature  
Switching tolerance  
Max pressure  
Housing  
OR gasket  
Electrical connection

NO (standard) - NC on request  
12÷24Vdc  
20A  
IP67 - DIN40050  
-20÷ +80°C  
-30÷ +90°C  
±3.5°C with ΔT ~1°C/min and environmental temperature 20÷25°C  
200 bar  
Brass  
NBR

Switch part number	A	Description
T16	1/2" BSP	50-40 12-24V
T17		60-50 12-24V

Temperature switch with soft start

#### Standard connector



#### Optional

KIT-WPC-M



Supply: bipolar wire length = 70cm (brown: positive / blu: negative)  
Load: bipolar wire length = 25cm with Metripack S280 female connector (terminal A: positive / B: negative)

## SS Serie / Zubehör

### SS Series / Accessories

#### Thermostat with speed regulator and reverse rotation program

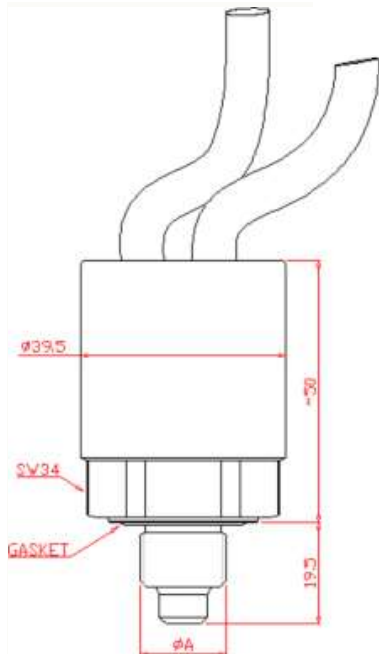

Switch part number	A	Description
T18	1/2" BSP	60-45 12-24V
T19		65-50 12-24V Thermostat with speed regulator and reverser on rotation

#### Standard connector



#### Optional

KIT-WPC-M



#### Technical features

Working temperature	-20°C ÷ +100°C
Switching accuracy	± 2°C
Weight	0,3 Kg
Body	in brass hexagonal, KEY34 with integral seal DIN
Electric features	Direct control to the electric engine for limiting the starting torque and the excessive energy during starting Standard execution power supply: 12-24 VDC Max load on contacts: 25A Electric protection according to DIN 40050, IP67
Standard electric wiring	Power supply: bipolar wire 1mm Signal: bipolar wire 0.35mm without connector
Warranty	see dedicated page
Spare parts	see dedicated page
Also Available	Different wire length Special electrical connection CU-TR for Russian market

On the instrument are settled the value of engine's start and the value at which the engine reaches the max speed. Within these values of temperature the engine speed adapts automatically to every temperature variations. The electric engine starts in a "soft-start" condition, with a progressive increase of the rotation during 30" or following a specific request indicated by the customer before the order. In addition this series includes a timed program that reverses the rotation of the engine: after 9 minutes of operative direction of rotation the engine stops, within 15" restarts and rotate for 60" with the opposite direction of rotation, then stops again and restart with the operative direction for 9 minutes. The instrument is made in one part in Brass that will be connected directly in contact with the fluid that need to be checked.

## SS Serie / Verwendung und Wartung SS-ST-SD-SSPV-SSV

### SS Series / Use and maintenance SS-ST-SD-SSPV-SSV

#### Installation

Air/oil heat exchangers are generally used for cooling oleodynamic equipments linked on the exhaust line where the exercise pressure isn't over 25 bar (max pressure admitted for air/oil heat exchangers). If the exhaust pressure is over 25 bar (flow multiplication, oil viscosity) the heat exchangers are placed into independent cooling systems with recirculation pump and by-pass.

It's advisable to mount the heat exchangers on anti-vibrants and to link inlets and outlets with flexible tubing. The heat exchangers must be installed in order that there aren't obstacles to the air flow: the anterior and posterior distance has to be as much or superior to the radius of the fan mounted (scheme 2).

If the oleodynamic equipment is placed in environments where the oil temperature is subject to high temperature range it's advisable to mount a by-pass valve since with low temperatures oil viscosity rises considerably causing high pressure drops that, in most cases, are bigger than the max pressure allowed. (scheme 1)

#### Electric part linking

Please be sure that Tension V, frequency Hz and rotation direction of the electric fan are as shown by the plate mounted on the heat exchangers. Follow accurately what's written in the electric scheme attached (scheme 3).

#### Air side maintenance

Disconnect electrically the heat exchanger. Disassemble the conveyor, electric fan and thermostat (if present). All the impurities can be removed with a warm water jet paying attention that its direction is parallel to the fins to help with the discharge of the dirt.

#### Oil side maintenance

Disconnect hydraulically the heat exchanger; flux against the flow the heat exchanger with degreasing substances not aggressive for aluminium. The intensity of the dirt will determine the duration of this operation that usually lasts from 15 to 30 minutes. In case the desired cleaning isn't achieved repeat the operation as many times as needed.



# SS Serie / Luft-Öl Version

## SS Series / Air-Oil Version

Scheme 1 SSV / SSPV

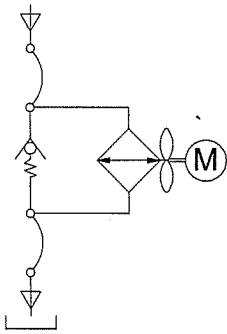

SSV / SSPV

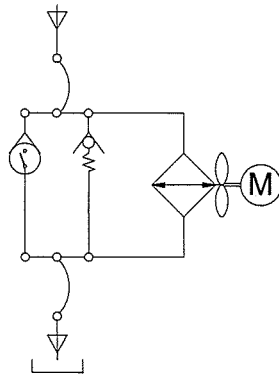

Scheme 2

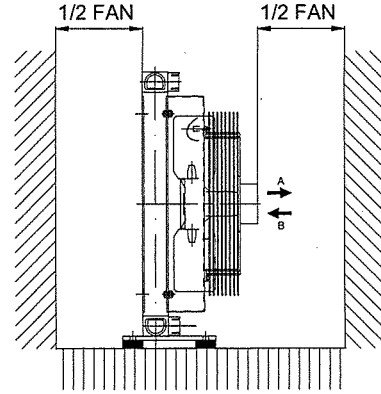

Scheme 3

230 V AC MON. ELECTRIC WIRING

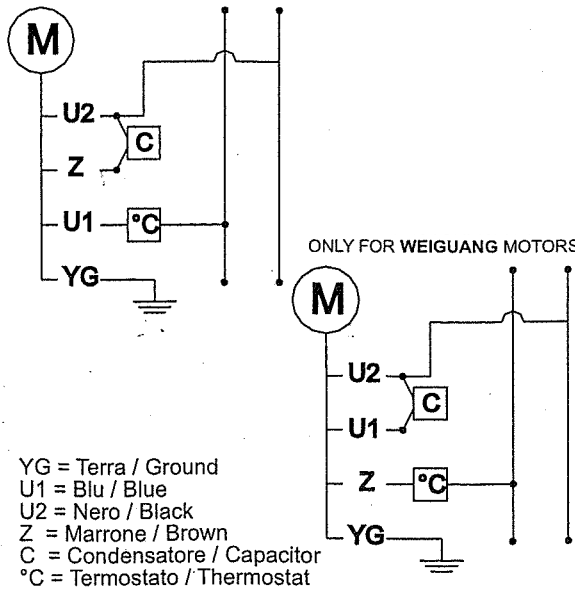

12-24 V DC ELECTRIC WIRING

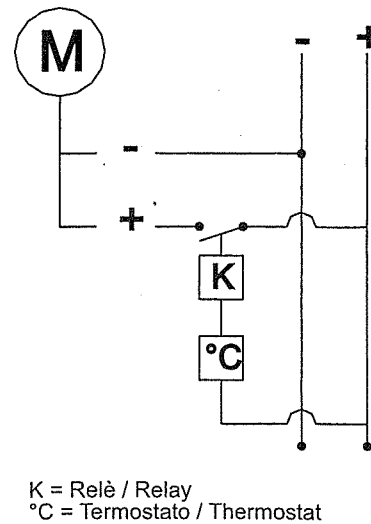

230V AC THREEPHASE ELECTRIC WIRING

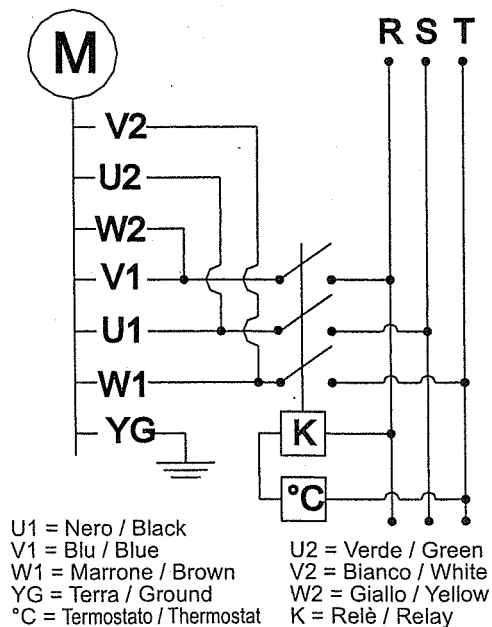

400V AC THREEPHASE ELECTRIC WIRING

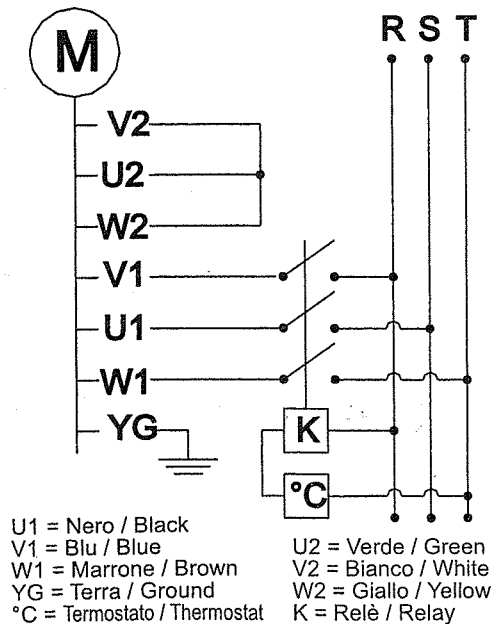

Öl-Kühler / Oil coolers



# Weitere Kühler:



**Wärmetauscher SSPV**  
Heat Exchangers SSPV



**Öl-Wasser-Kühler / Oil-water-cooler**

Typenbezeichnung		Model type	
<b>Plattenwärmetauscher</b> Brazed plate heat exchanger			
BLT B 25 - 50			
Siehe Tabelle / see diagram	Kühlertyp / type of cooler	Plattenzahl / number of plates	Siehe Tabelle / see diagram
Material Spezifikation / material specification		Technische Spezifikation / technical specification	
Platten / plates	Edelstahl 1.4401 / stainless steel 1.4401	Max. Betriebsdruck Ölseite u. Wasserseite / max. operating pressure oil and waterside	27 bar
Anschlüsse / connection ports		Max. Betriebstemperatur / max. operating temperature	225 °C
Lot / solder	Kupfer / copper 99,9 %		
<b>Rohrbündelwärmetauscher</b> Tube heat exchanger			
BLT - EKM - 1036 - O - CN - G11/2"			
Typ EKM	500, 700, 1000	Wasserrohre / water tubes	Öl-seitige Anschlüsse / oil connections
Baugröße / unit size Siehe Seite 72 / see page 72		CN = Kupfer/Nickel / copper/nickel CU = Kupfer / copper	
		Kühlwasserführung / cooling water connection system	O = 1-Weg / 1-pass T = 2-Weg / 2-pass



**Wärmetauscher**  
Heat Exchangers

**Luftkühler**  
Air coolers



**Wasserkühler**  
Oil-water-coolers



# Weitere Produkte:

**BLT HYDRAULIC COMPONENTS**

Hydraulikaggregate



Hydraulikaggregate  
Benzin/Diesel/Elektro



[www.berlitech.de](http://www.berlitech.de)

**BLT HYDRAULIC COMPONENTS**

Stahl- und Metallbau



- HYTANX® Behälter
- Ölwannen
- Maschinengestelle



[www.berlitech.de](http://www.berlitech.de)

**BLT HYDRAULIC COMPONENTS**

Hydraulikkomponenten



Komponenten für  
Hydraulikaggregate



[www.berlitech.de](http://www.berlitech.de)

BLT Hydraulic Components GmbH  
Emil-Rohrmann-Str. 2a  
D-58239 Schwerte  
Germany

02304 954 71 72  
[info@berlitech.de](mailto:info@berlitech.de)